

0000

<END>

0000

<END>



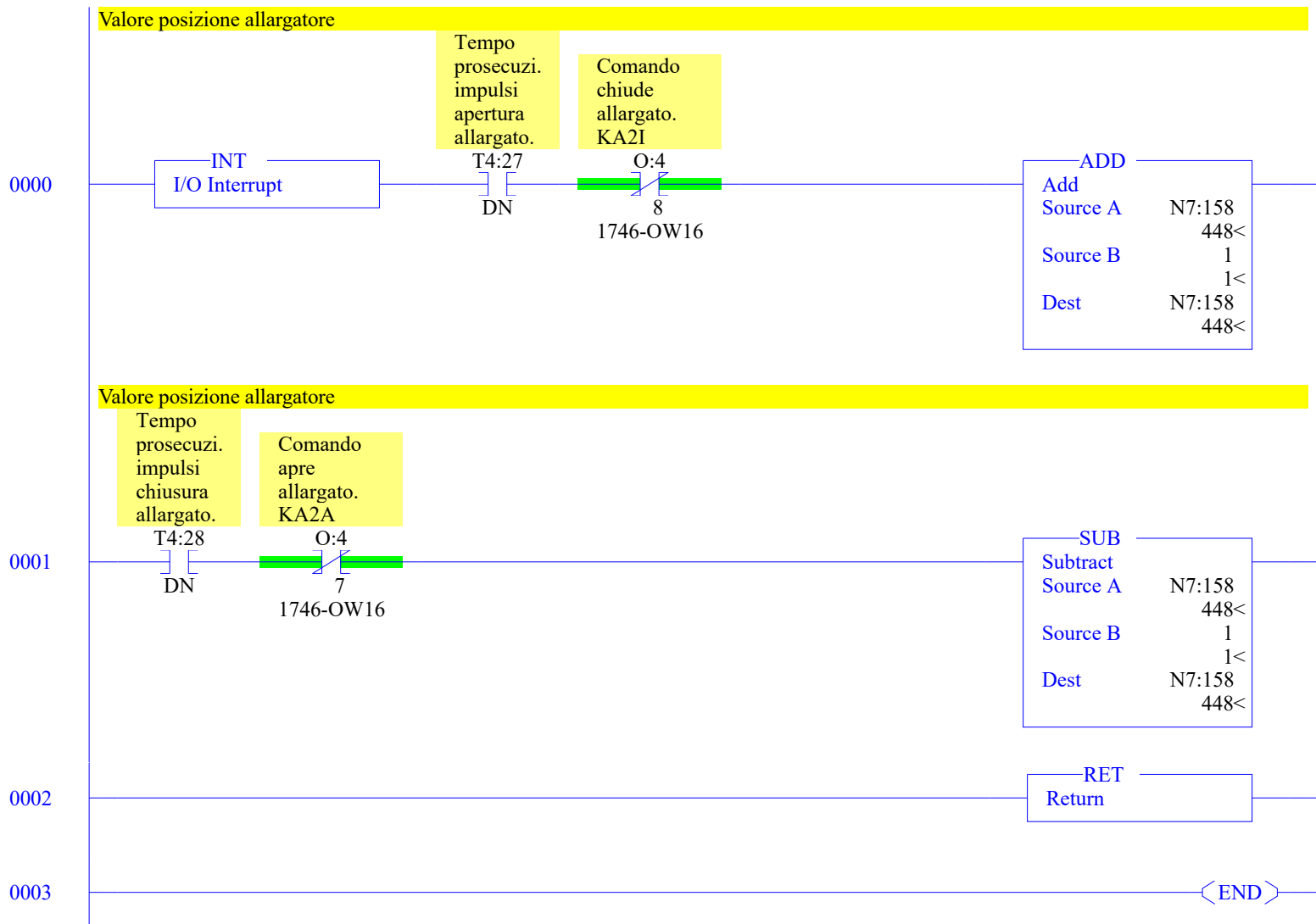

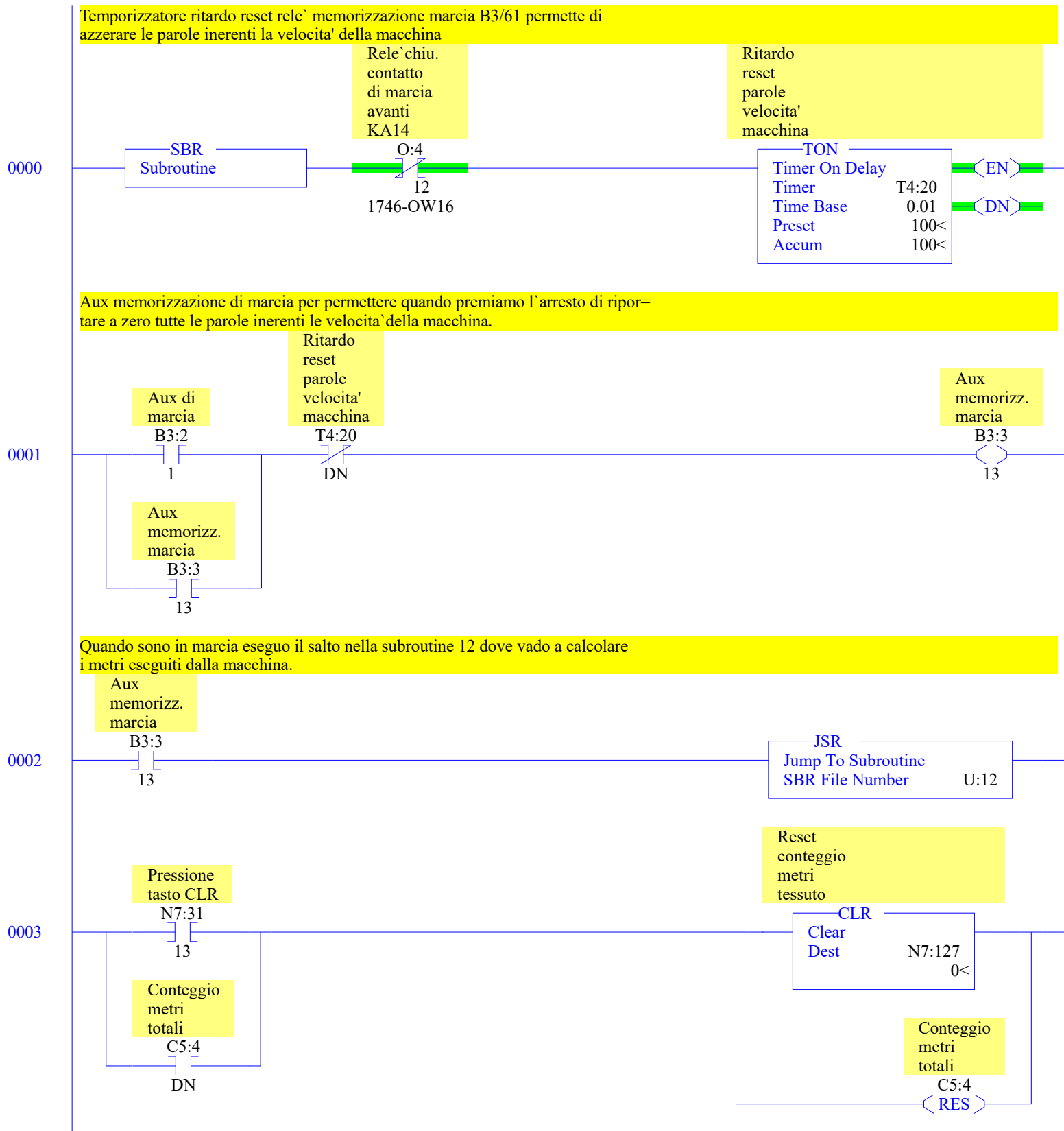



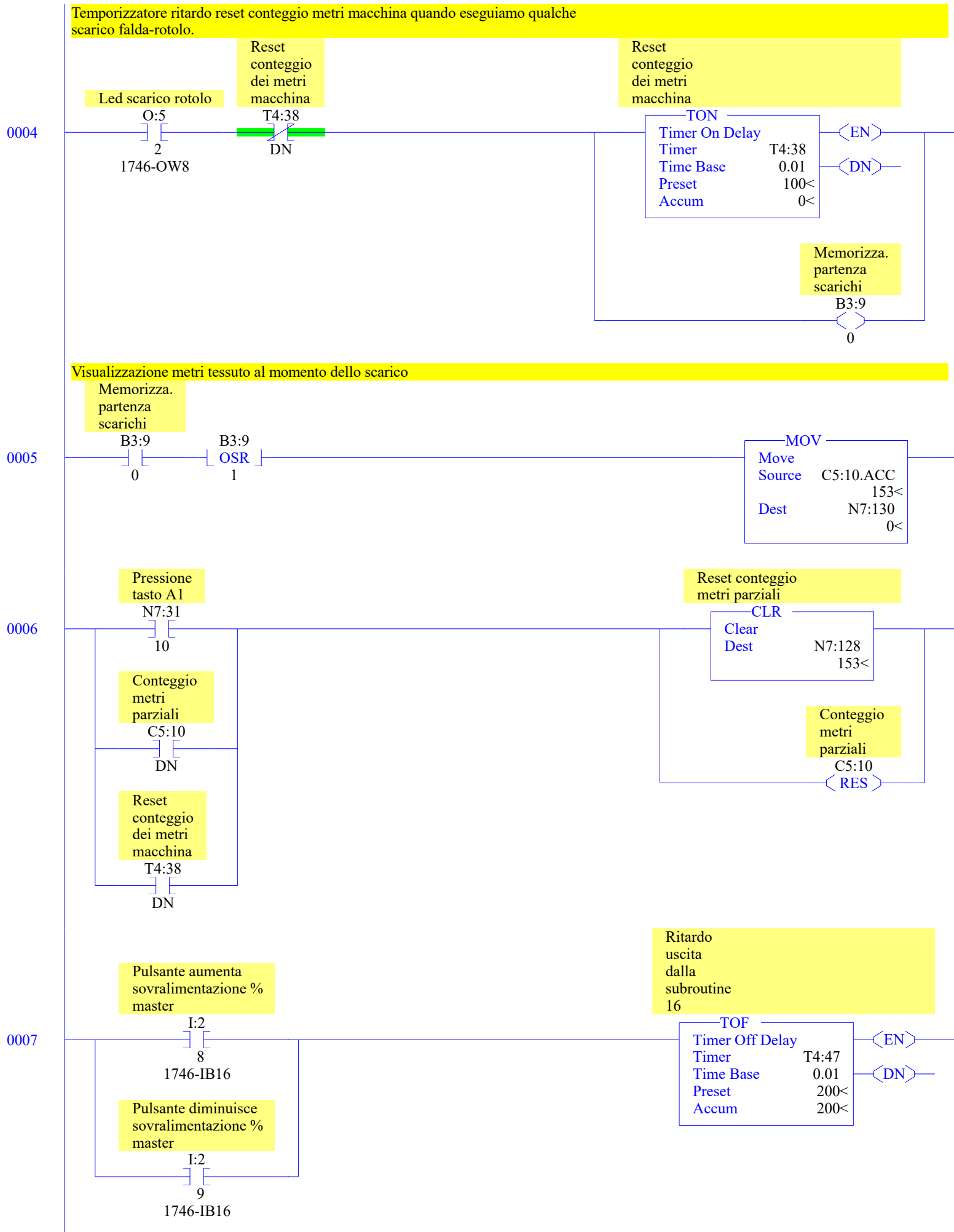

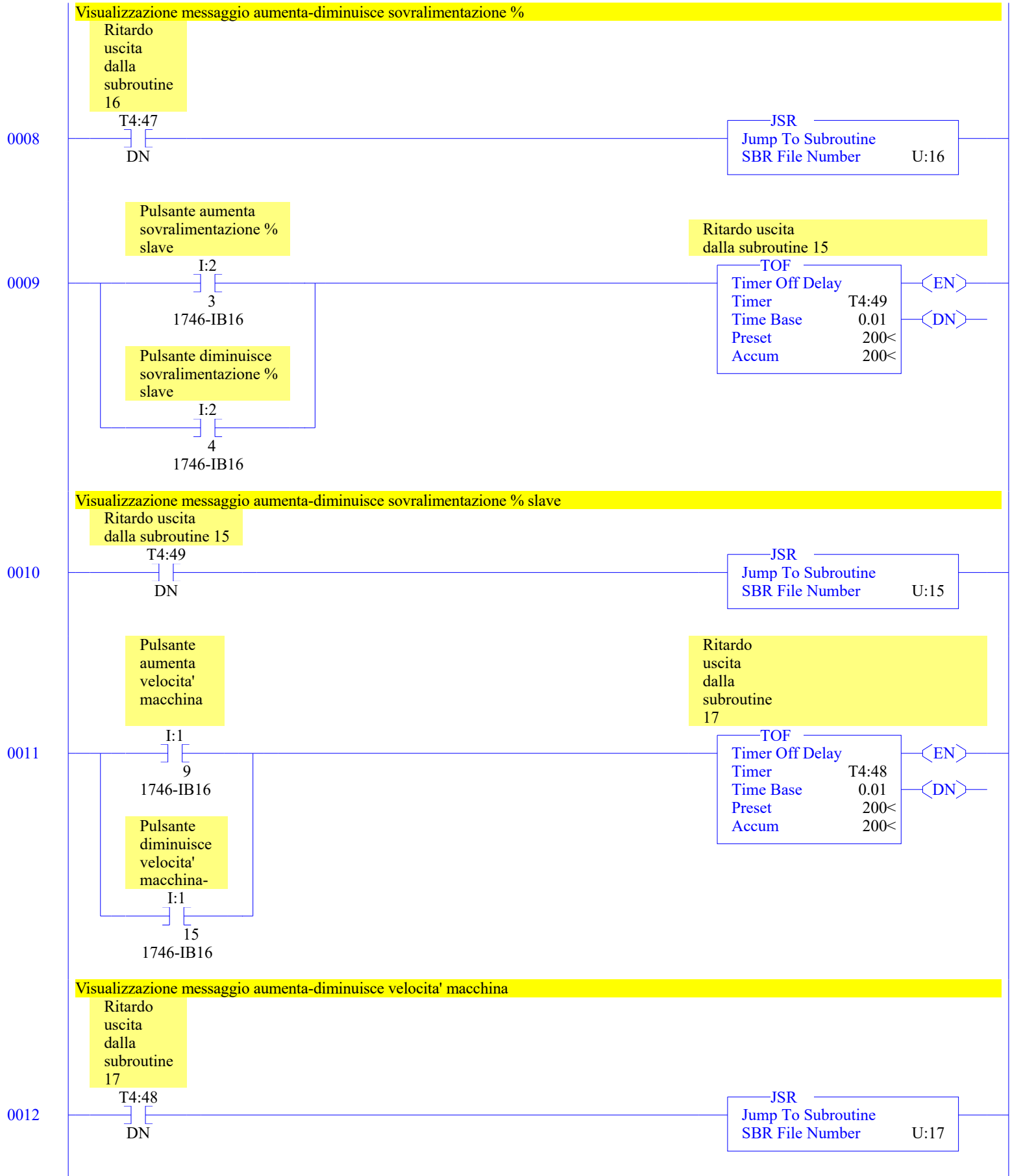

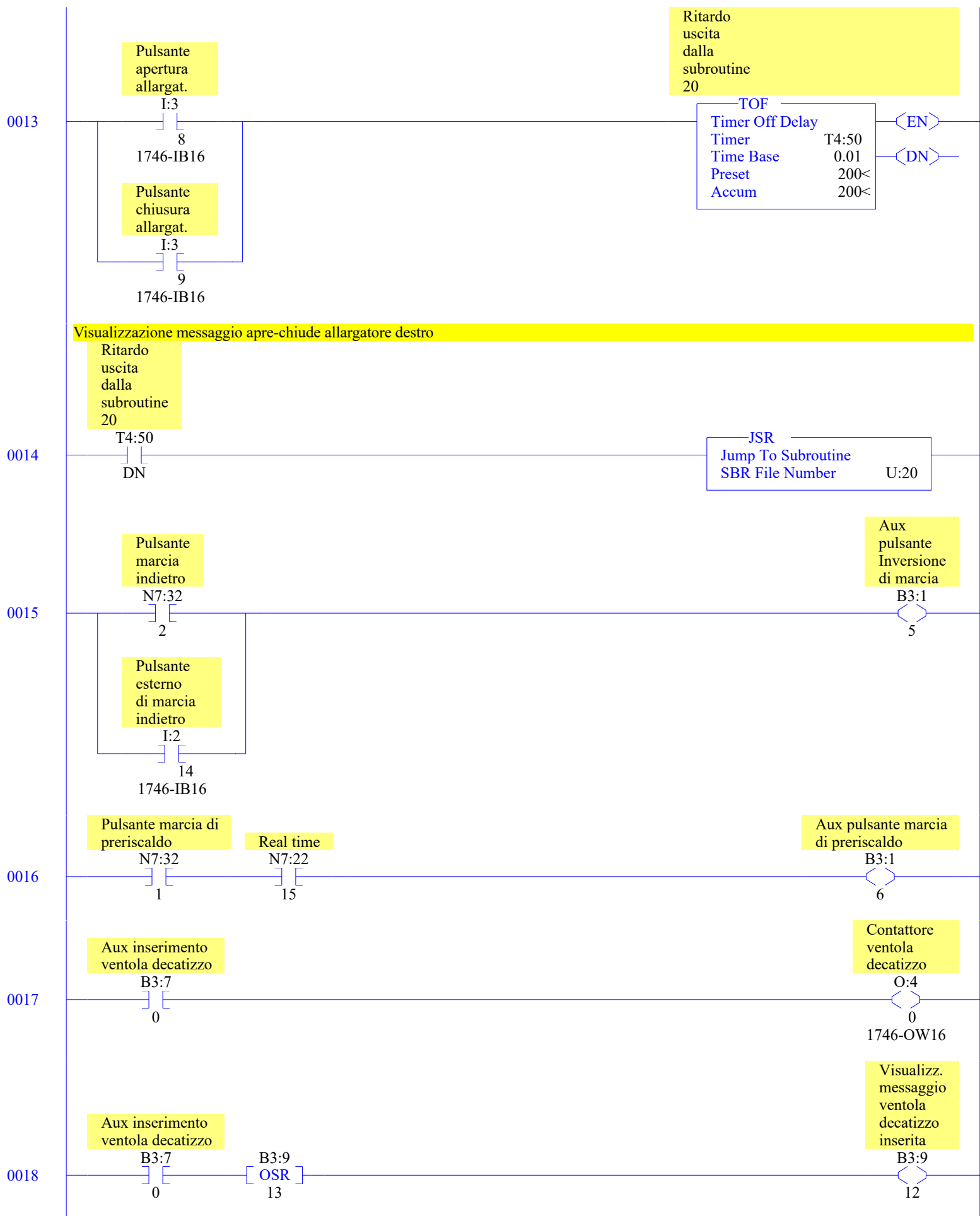

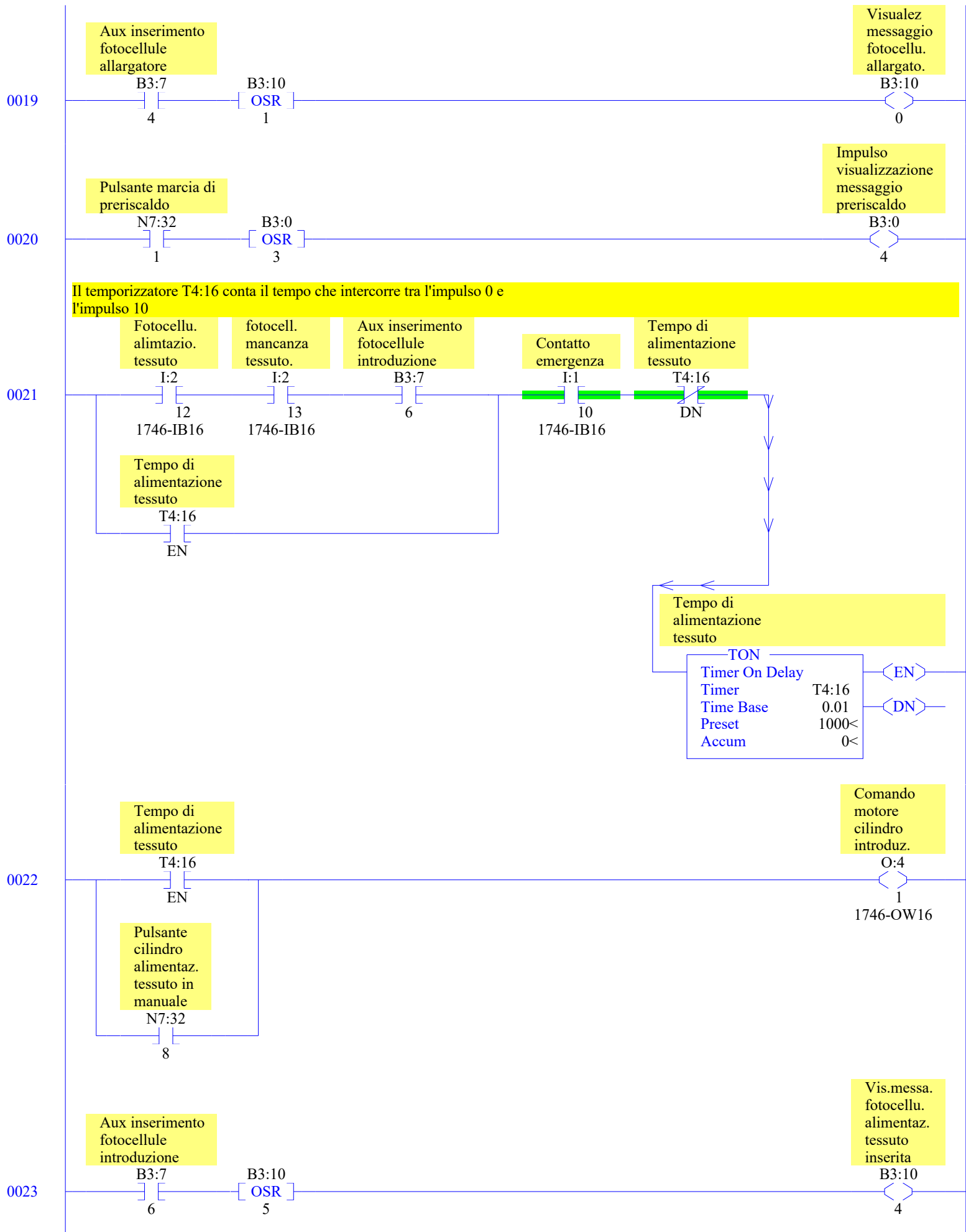

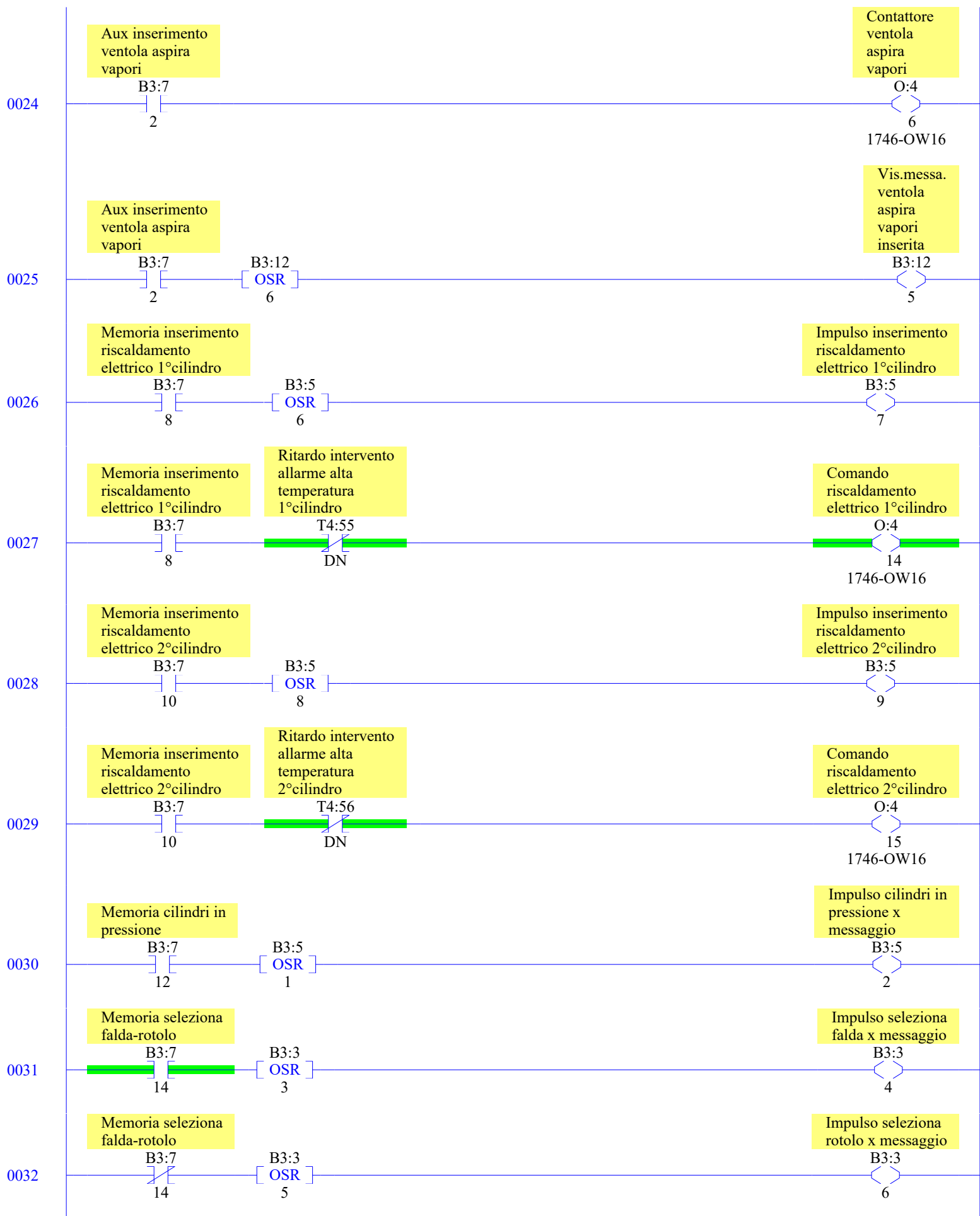

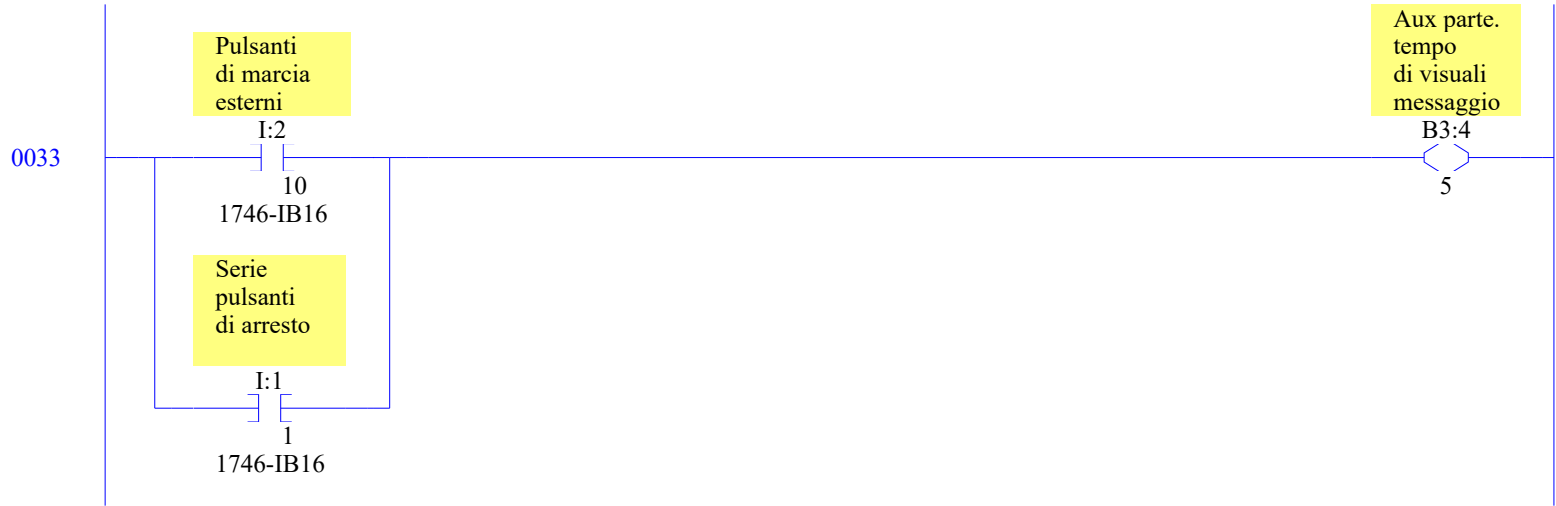

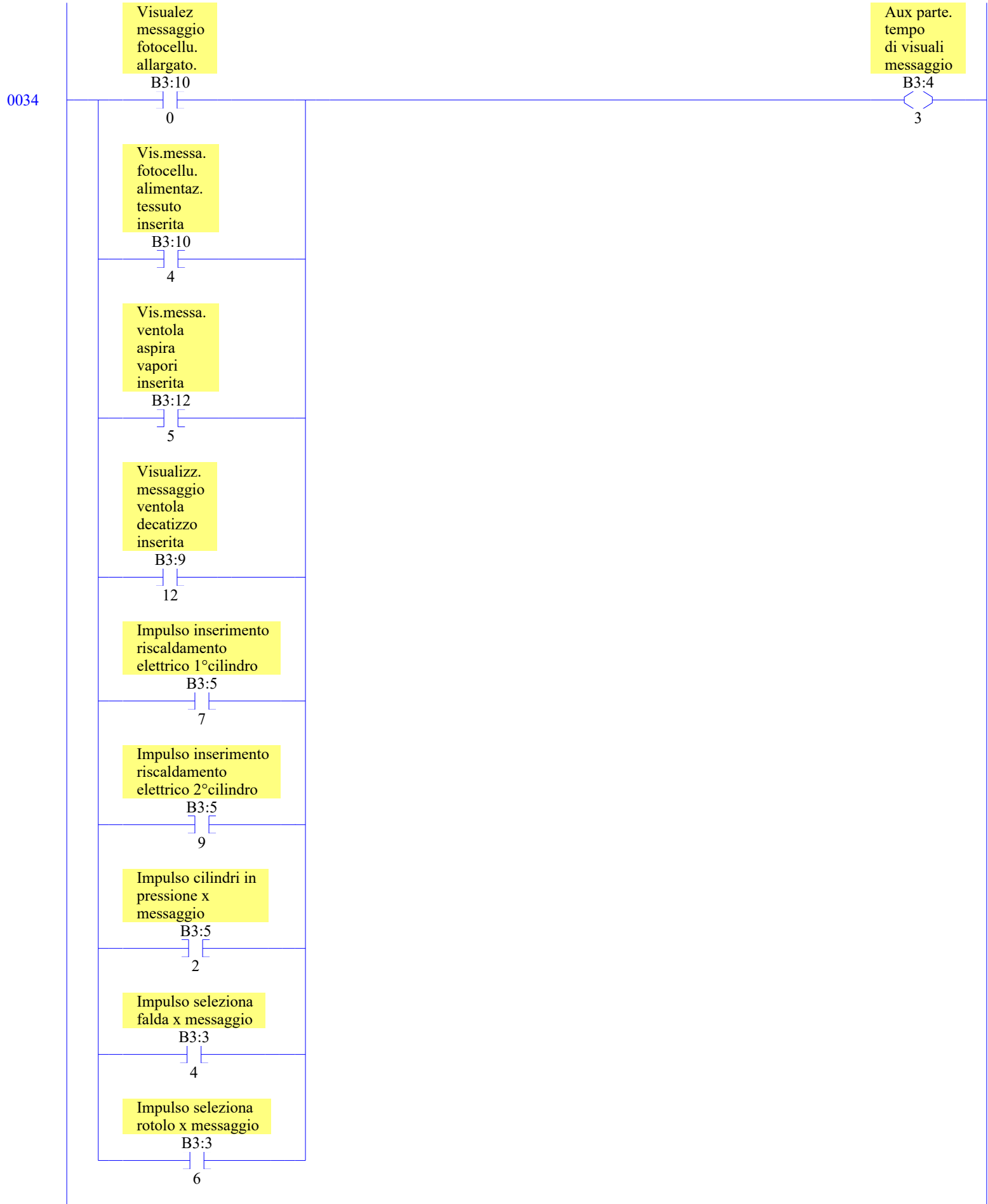

0035

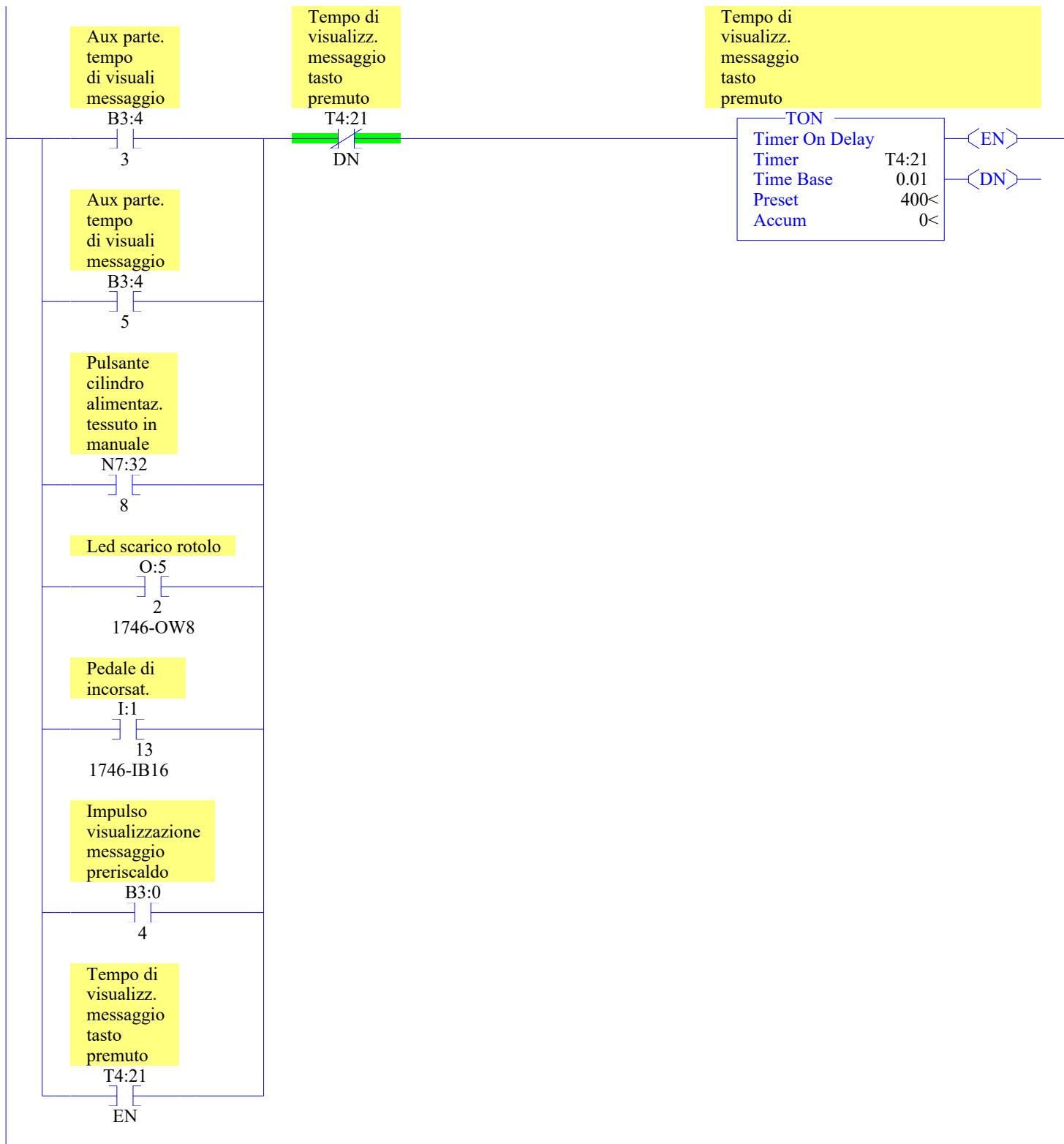



Con l'attivazione del merker B3/68 eseguo il salto nella subroutine 19 dove vado a visualizzare i messaggi dei tasti premuti.

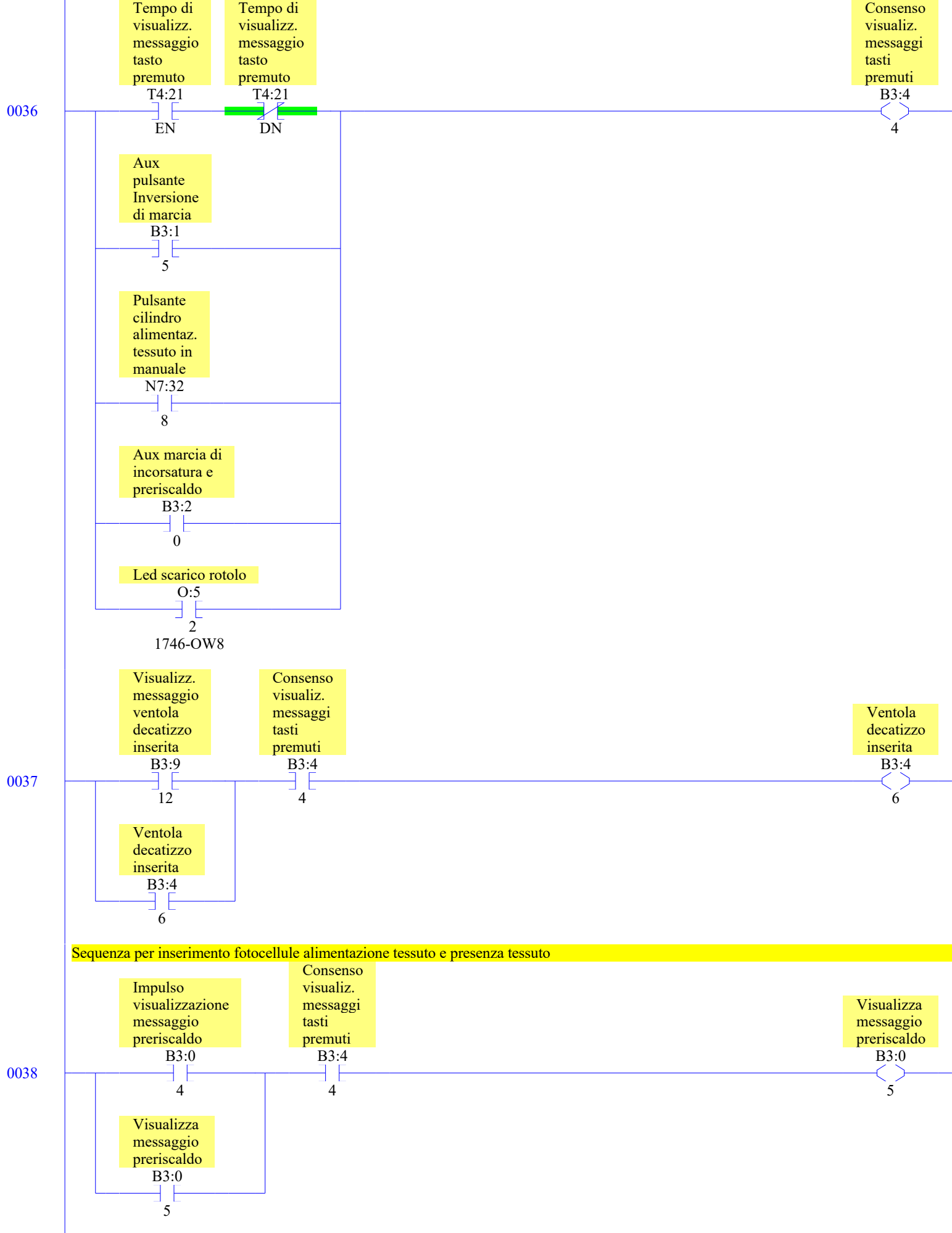

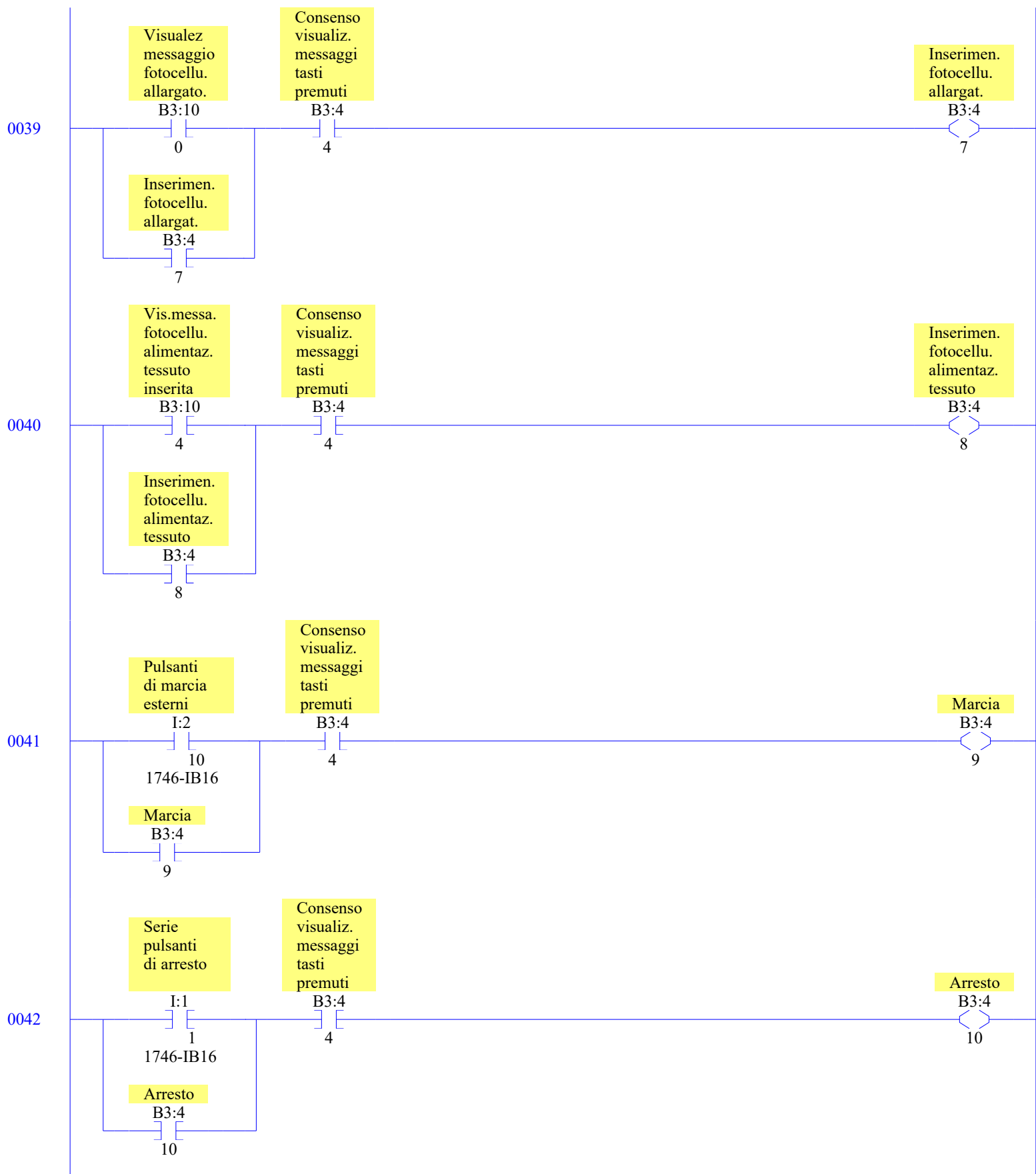

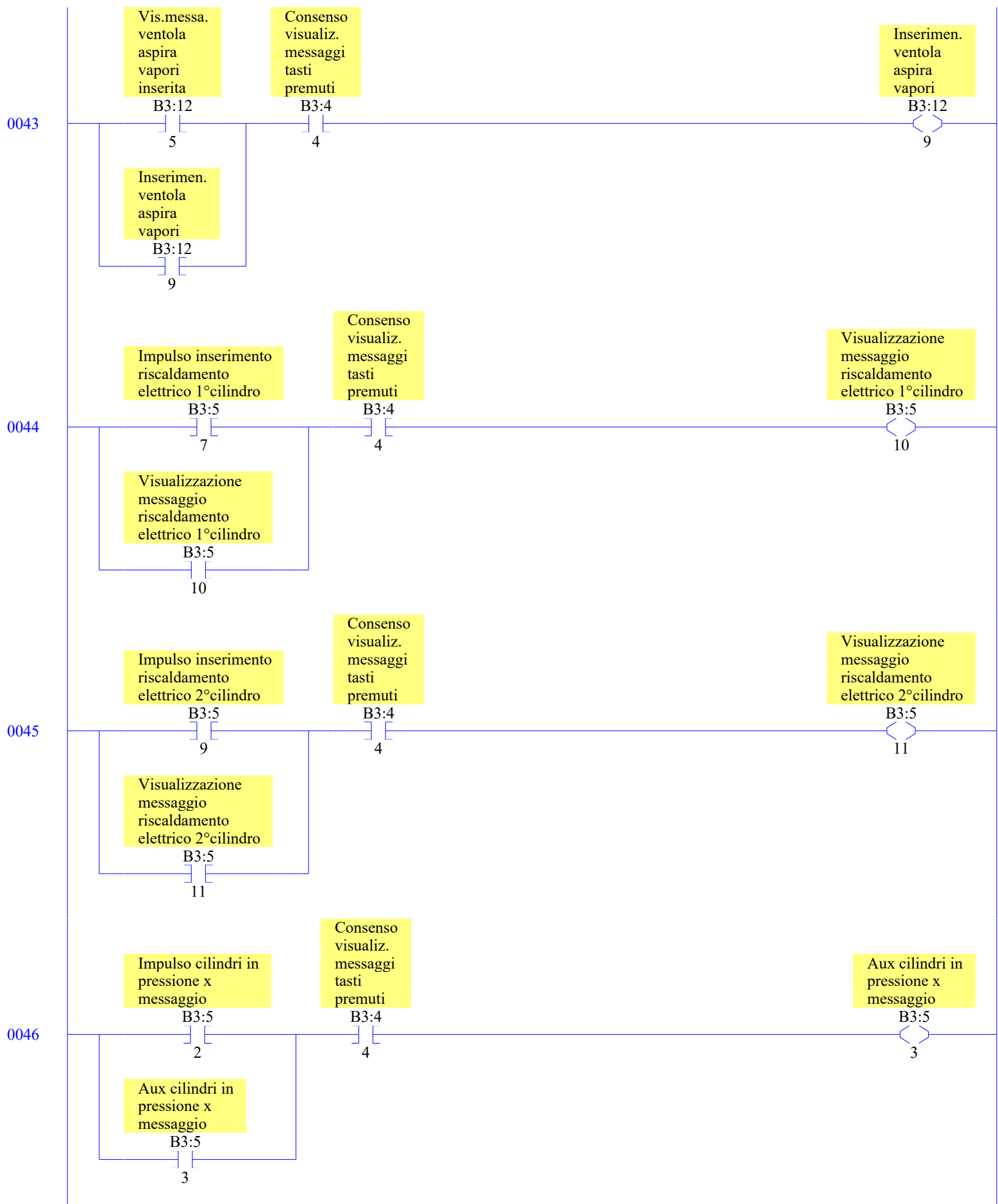

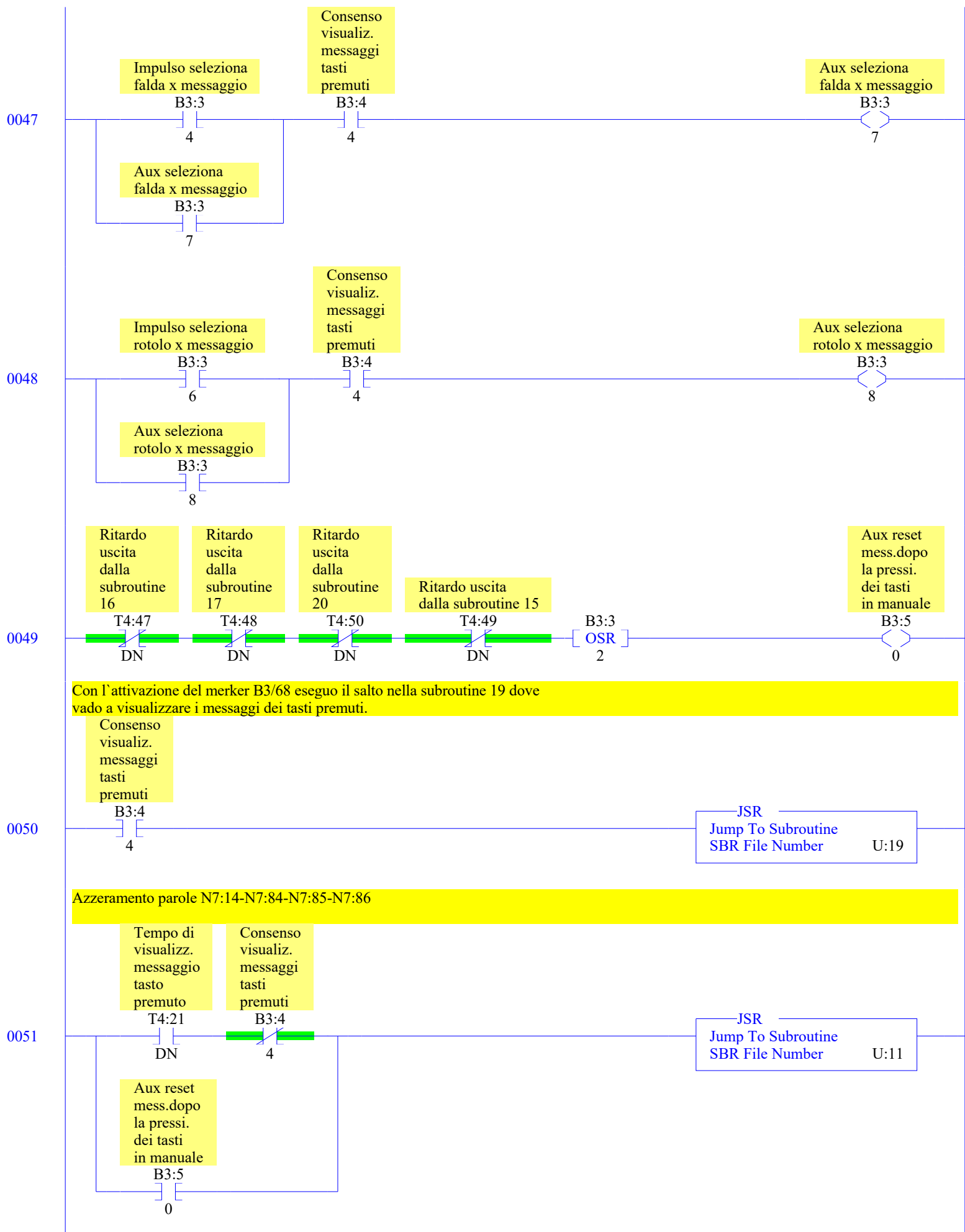

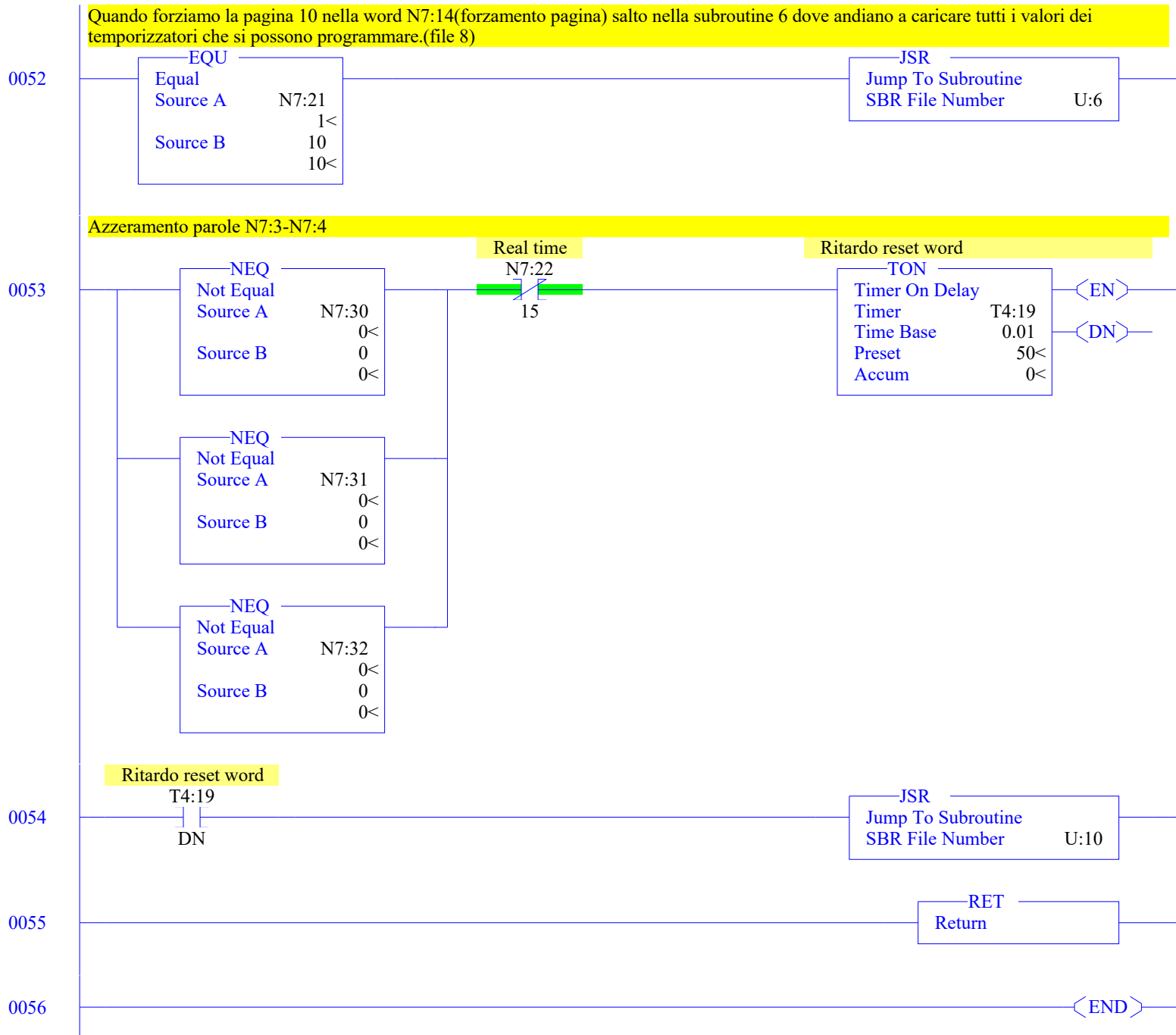

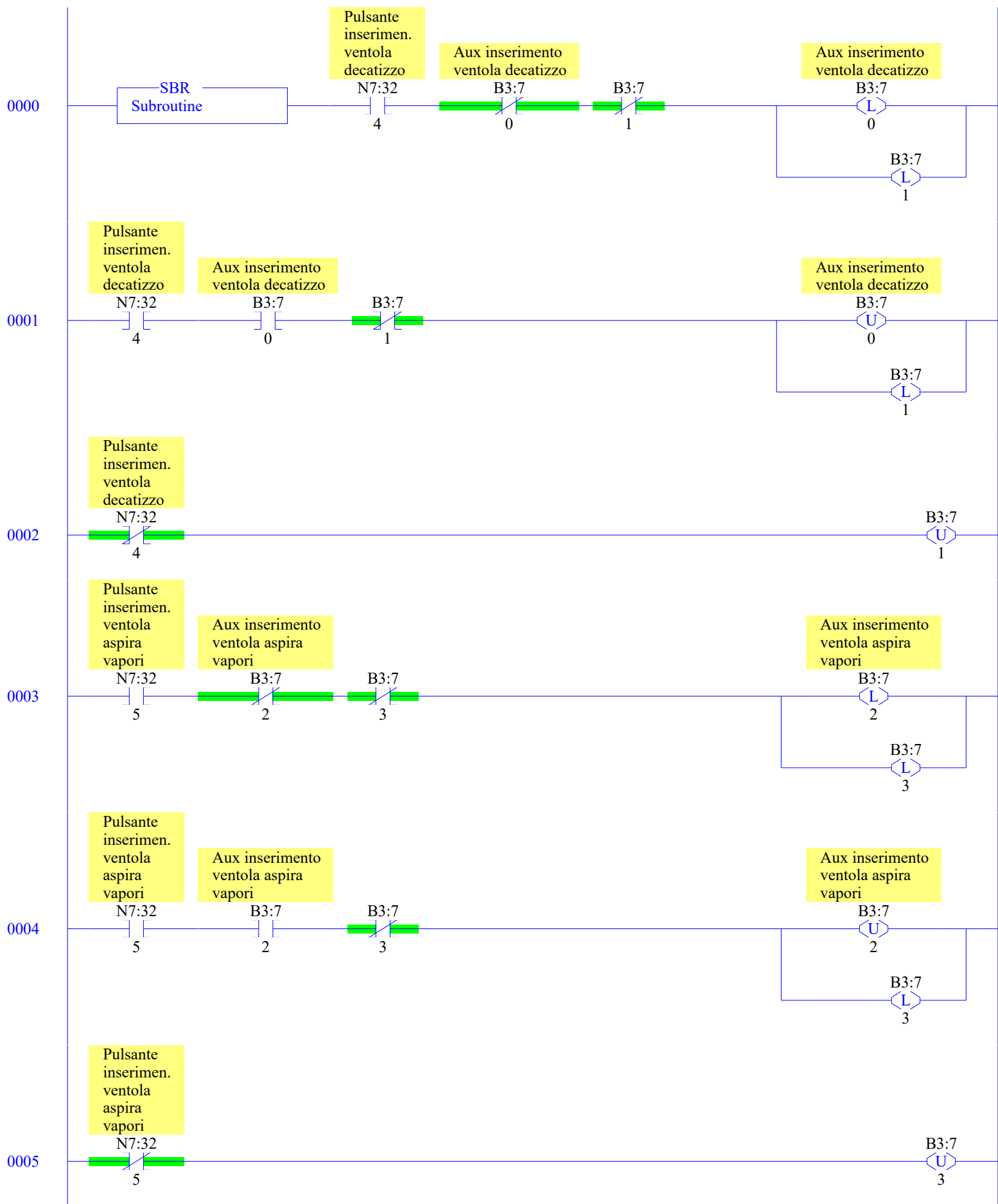

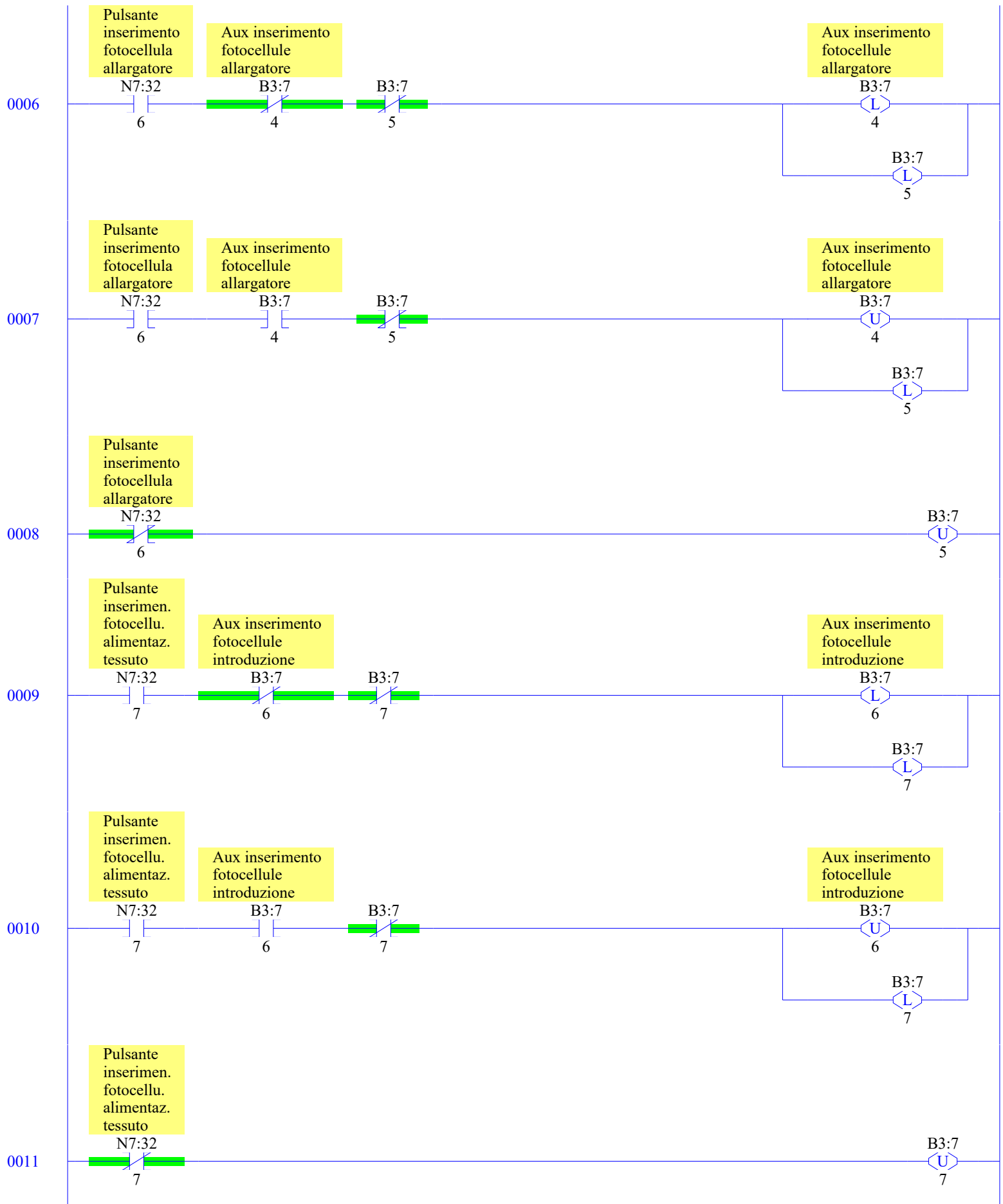

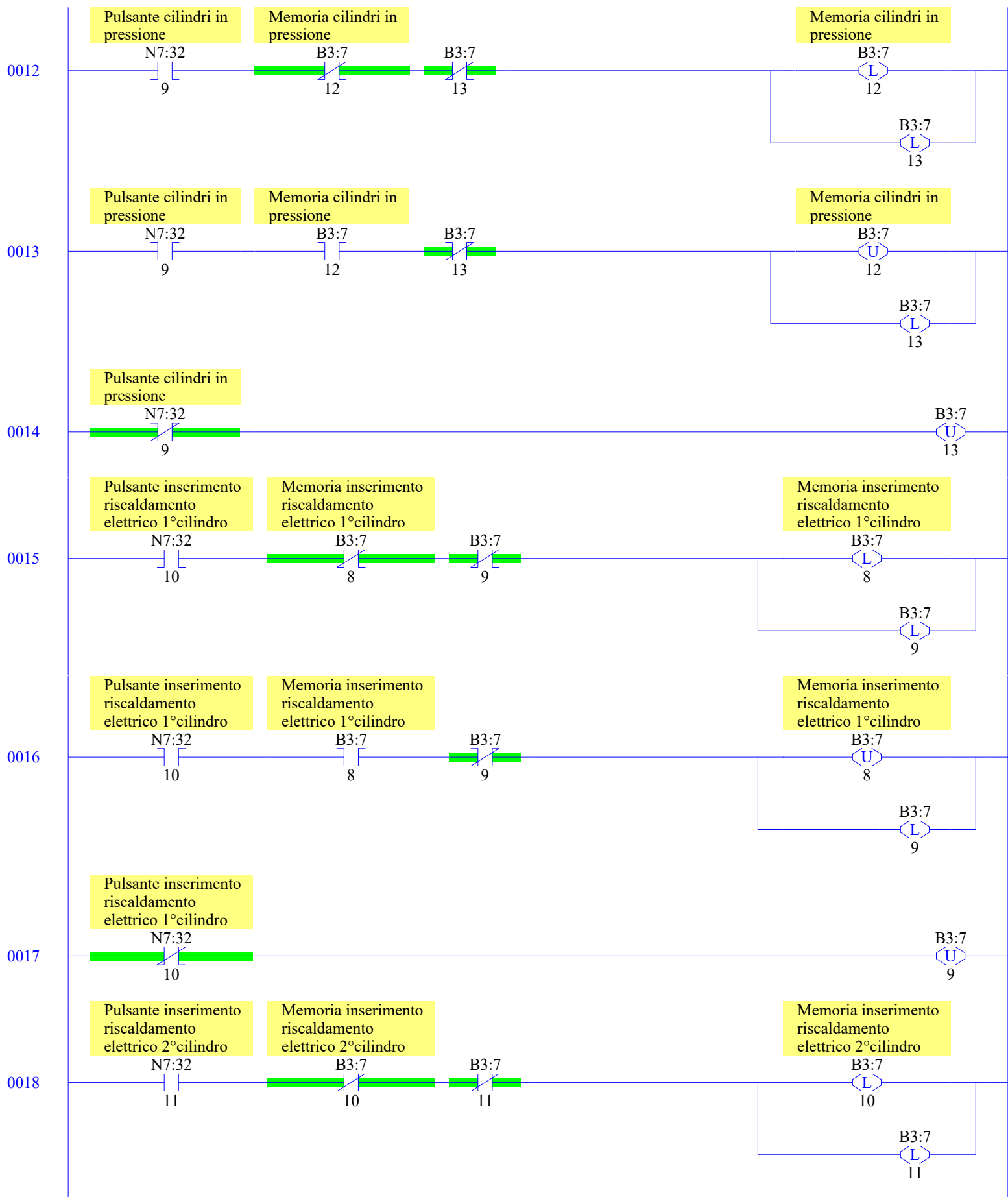



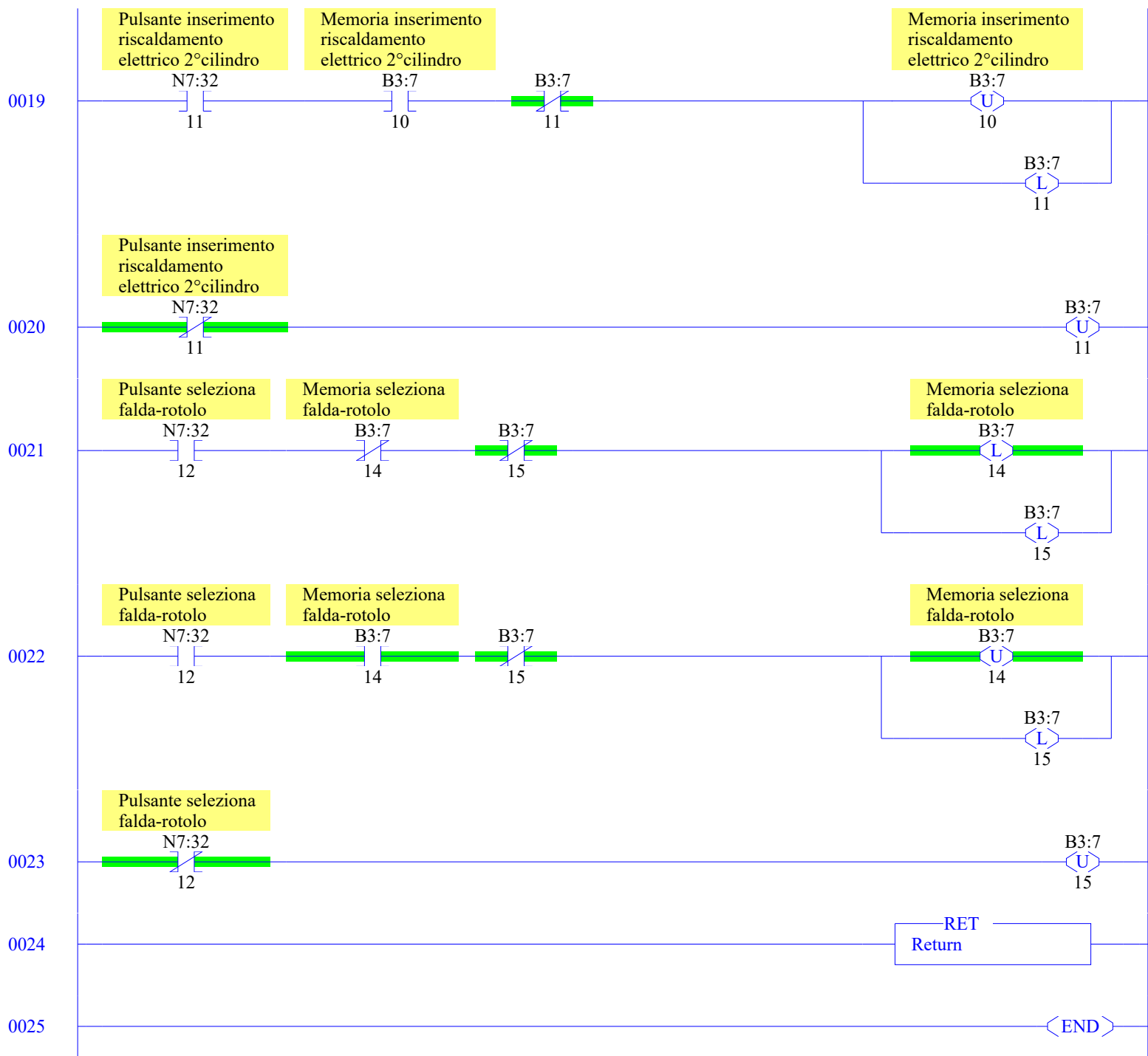

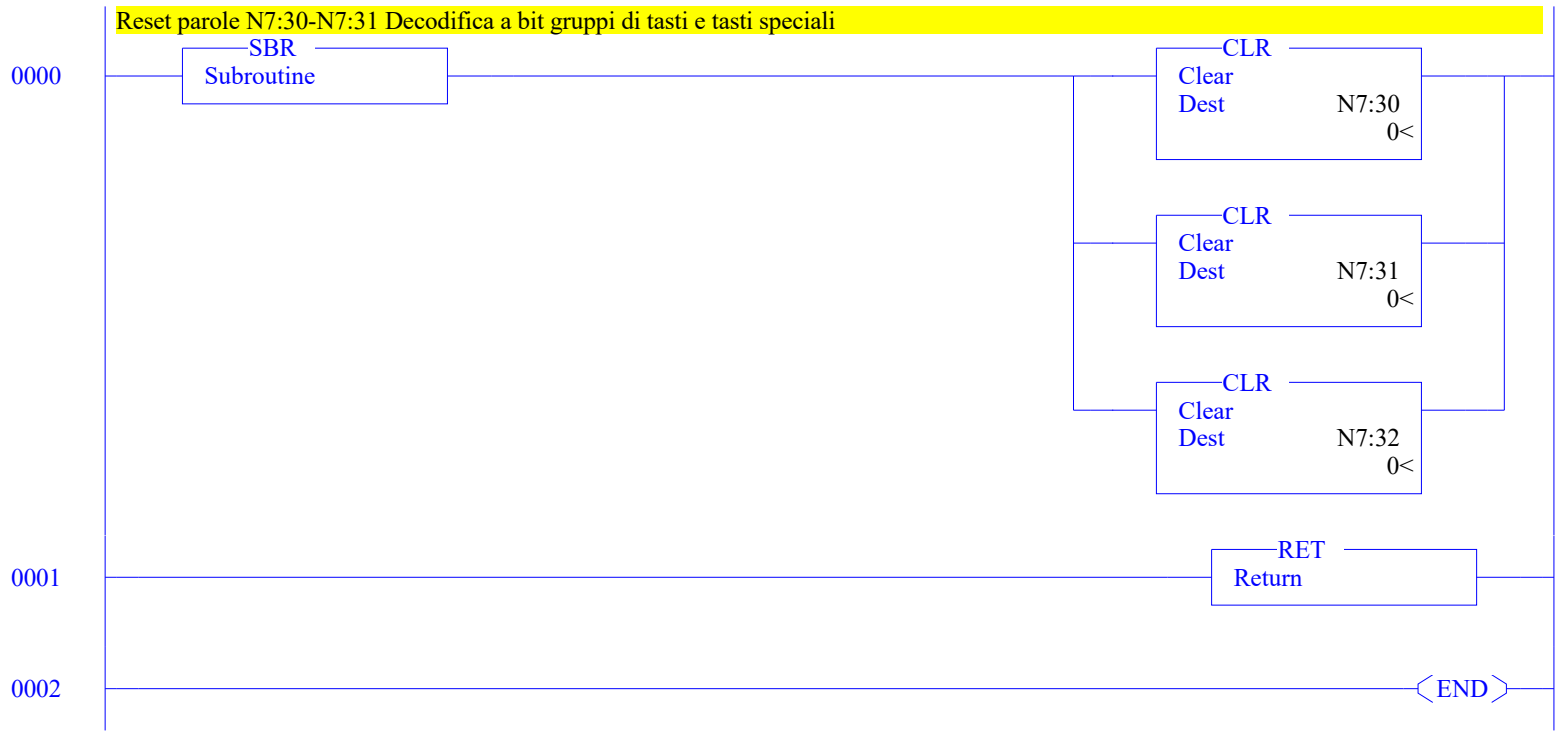

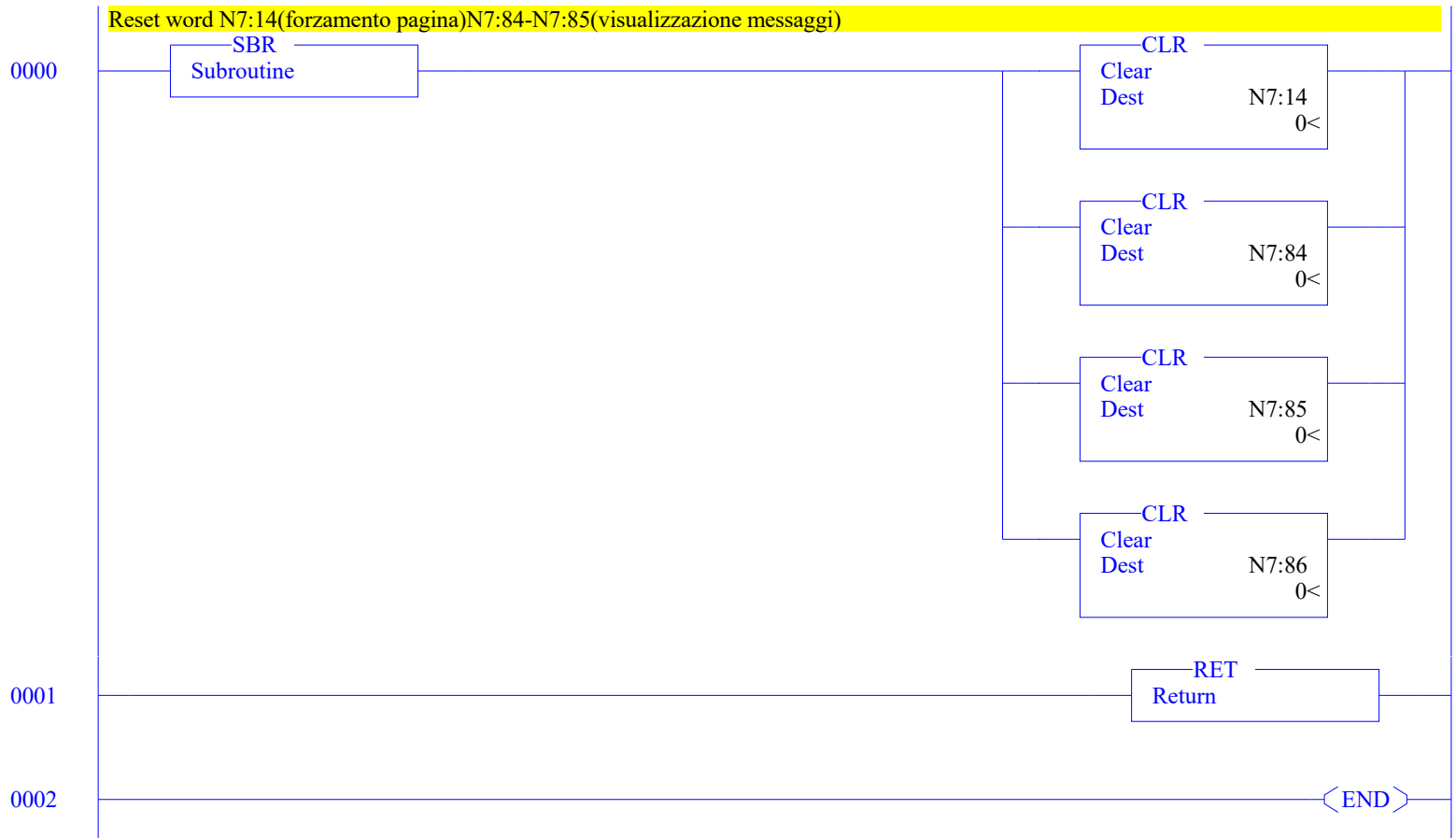

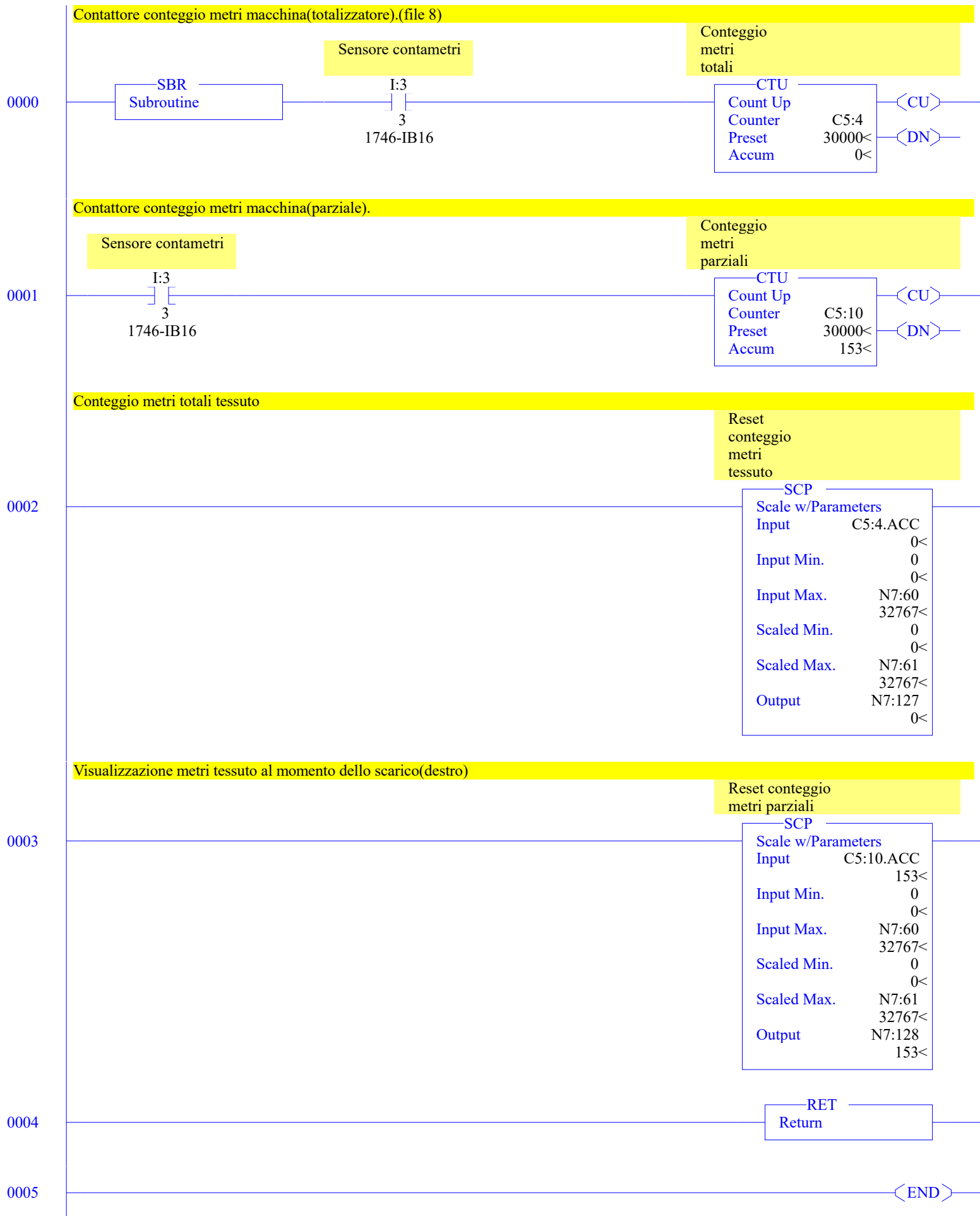

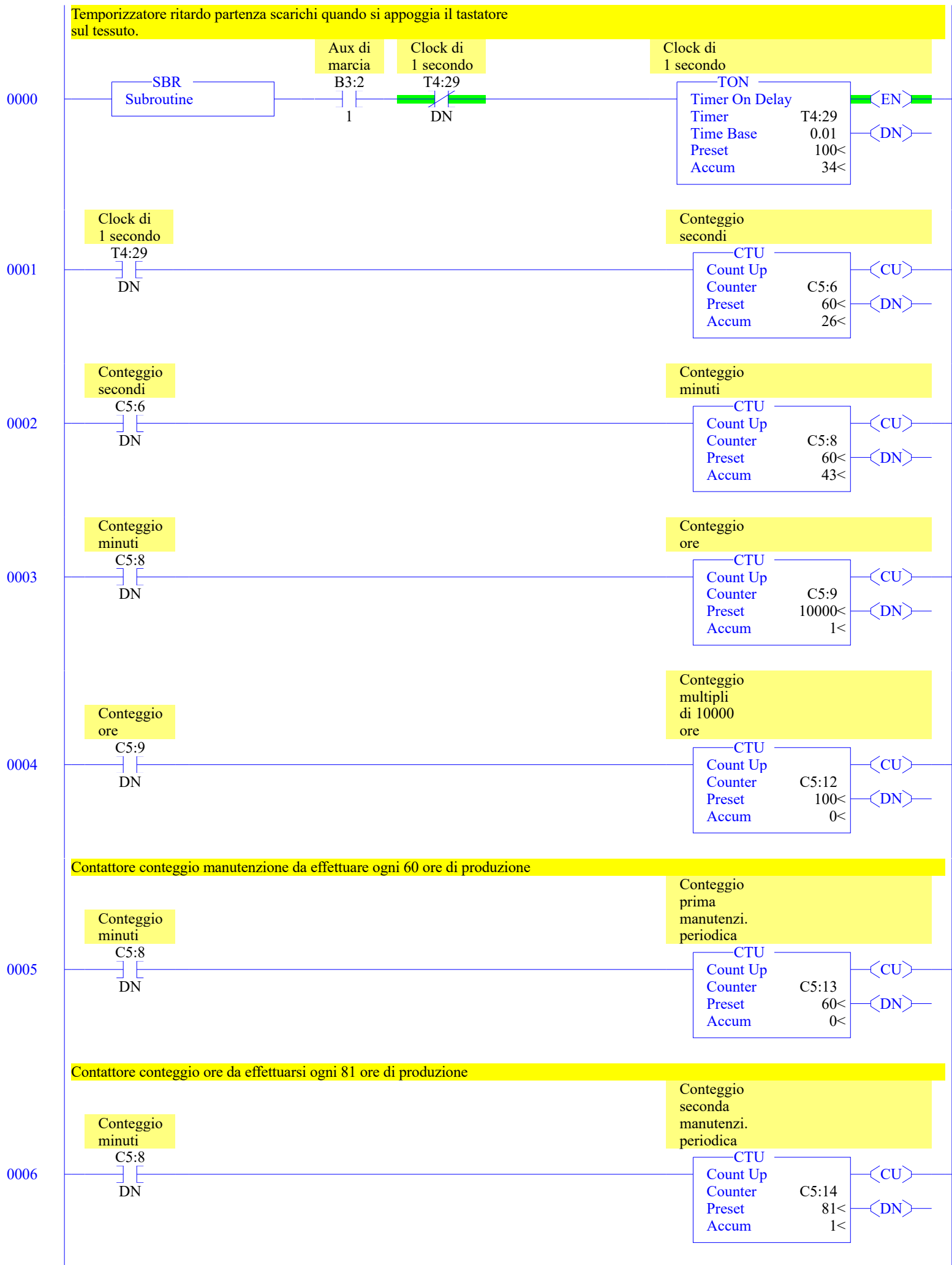



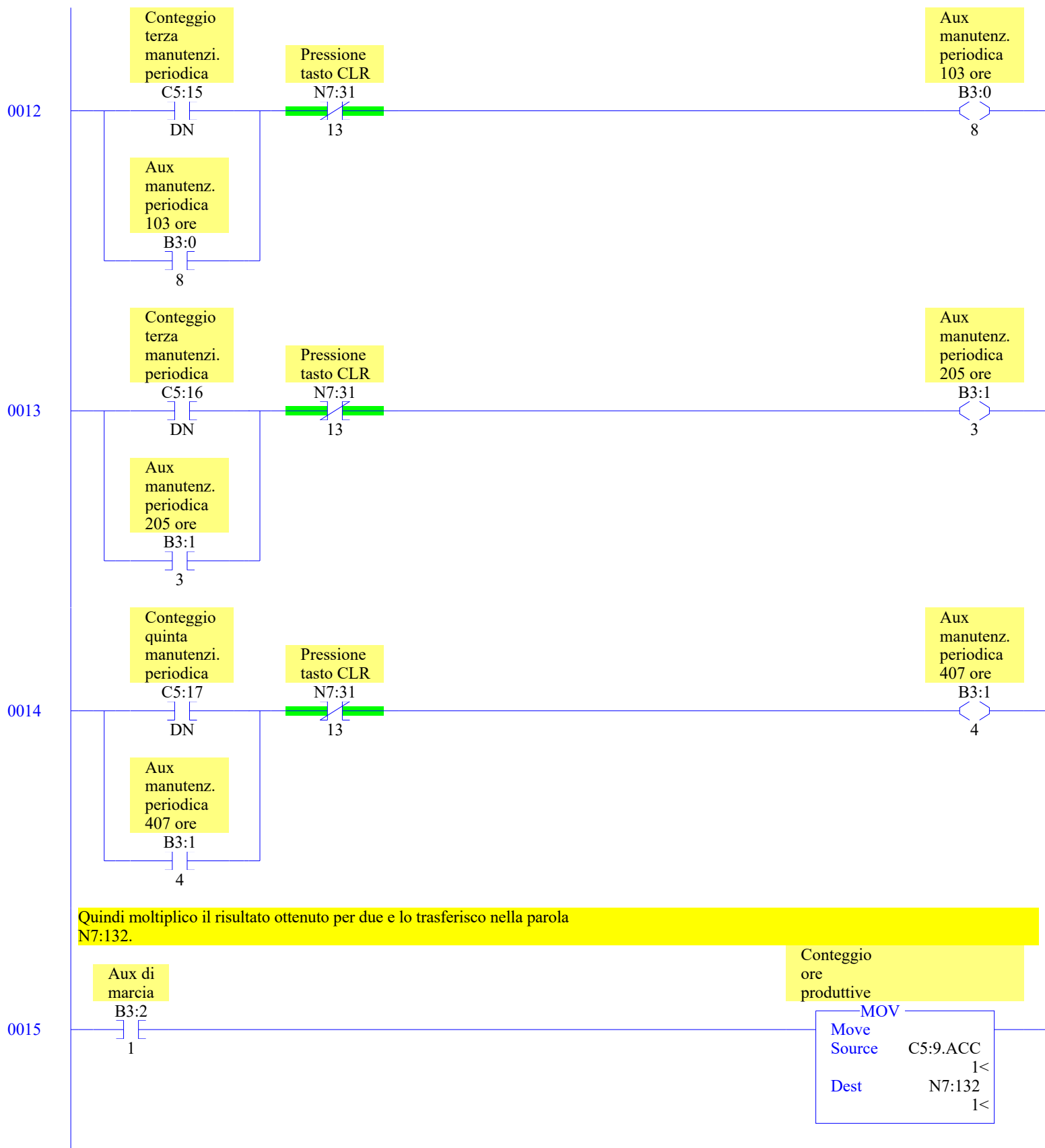





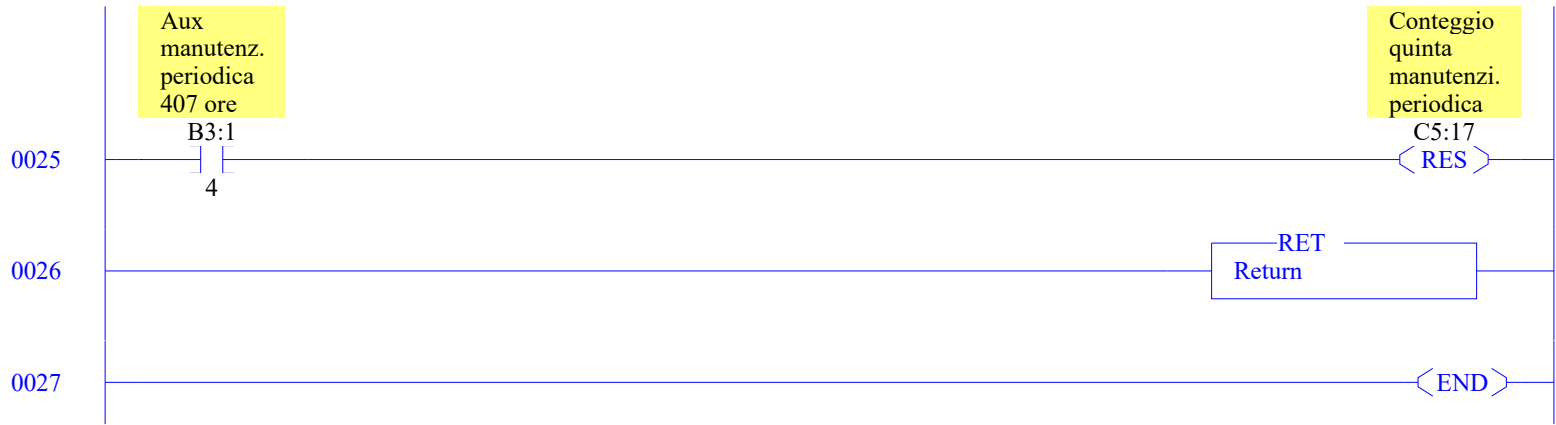



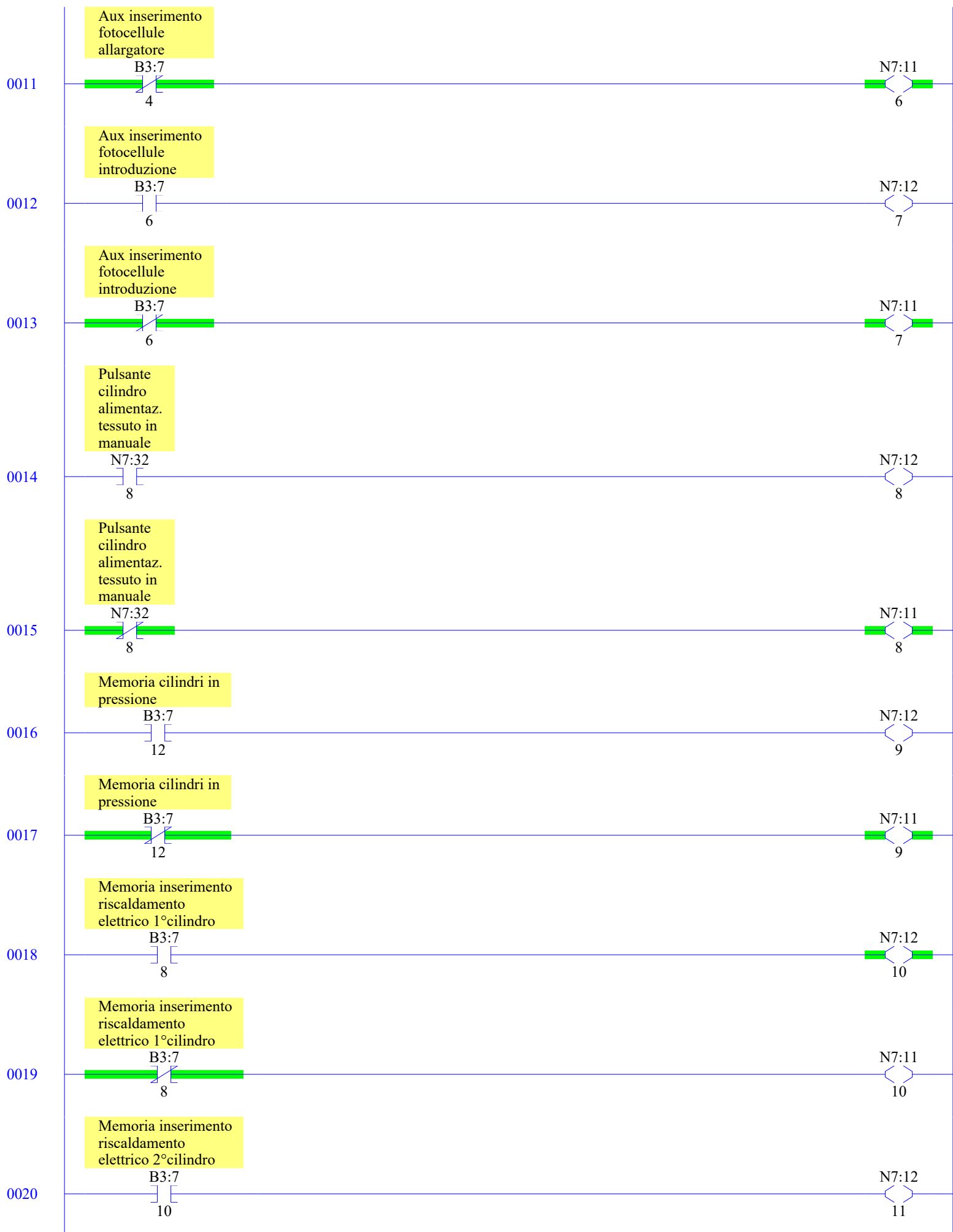

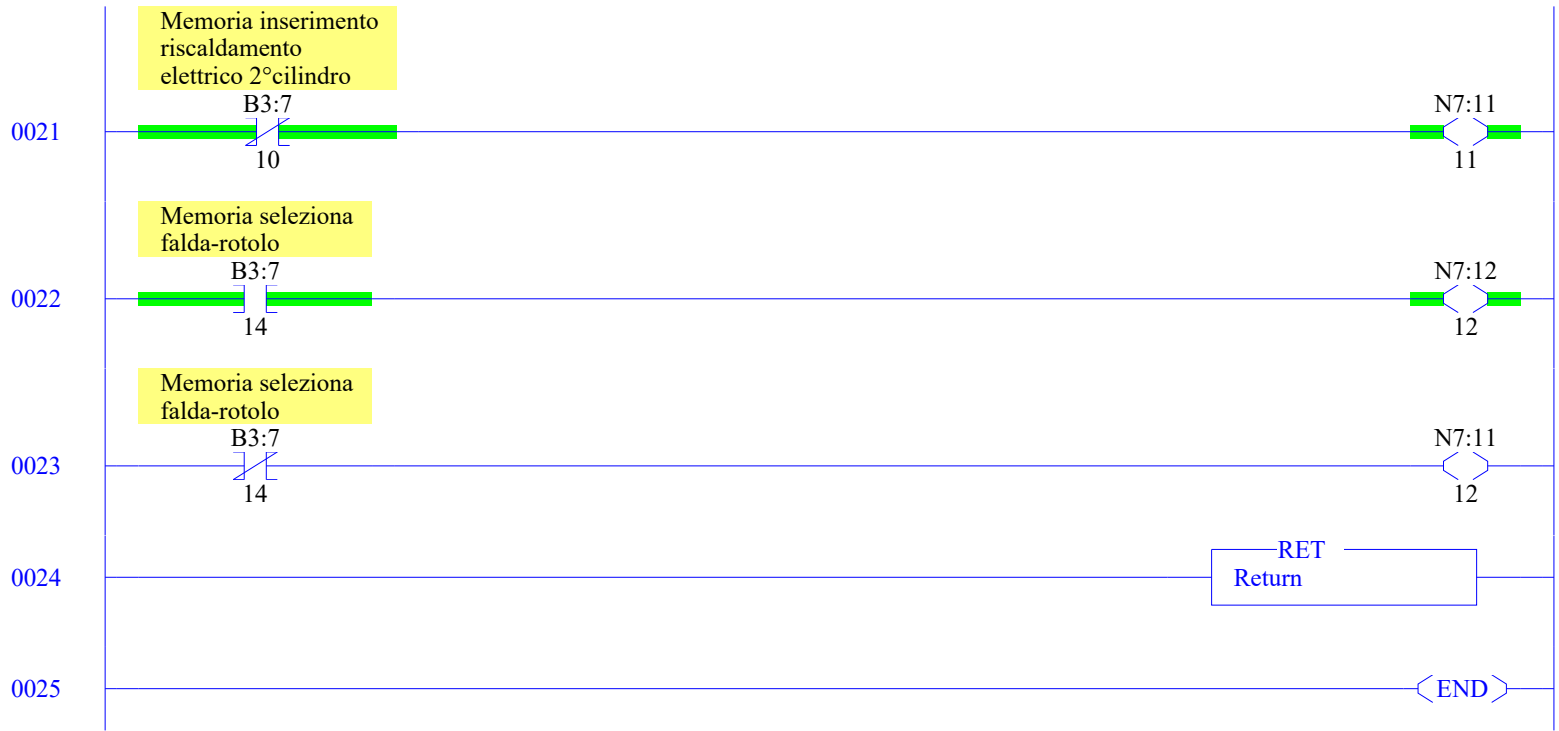

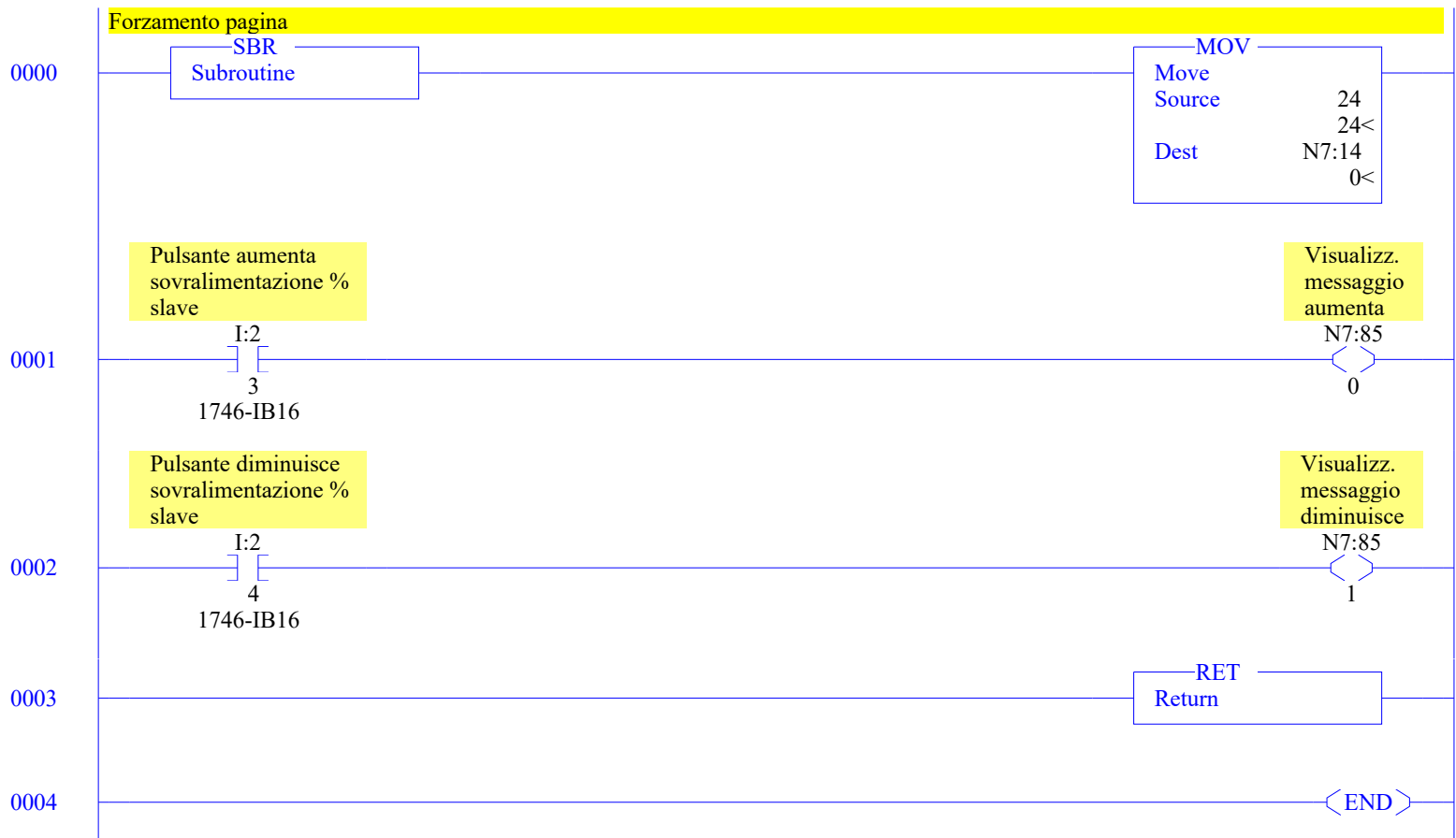

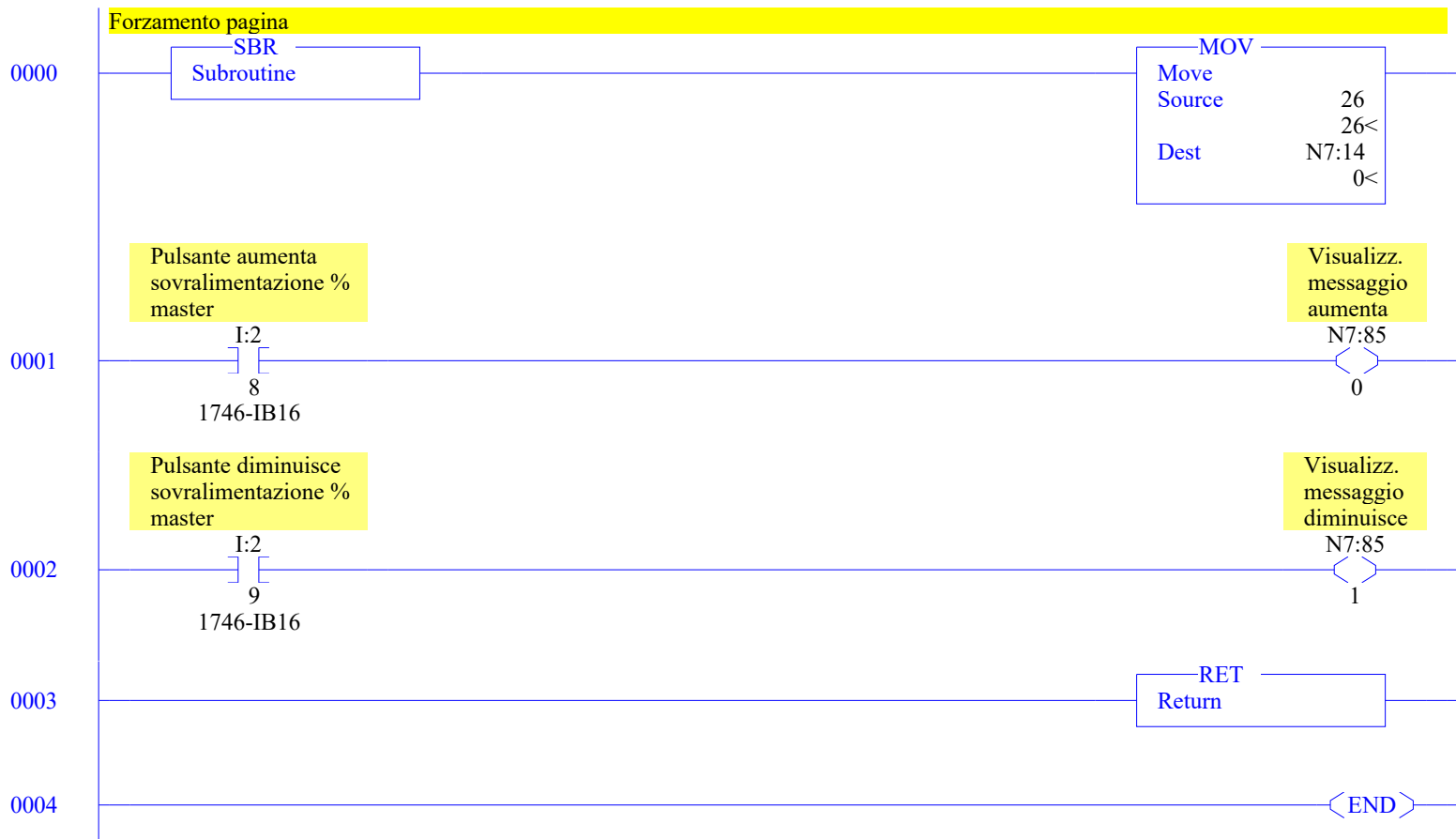

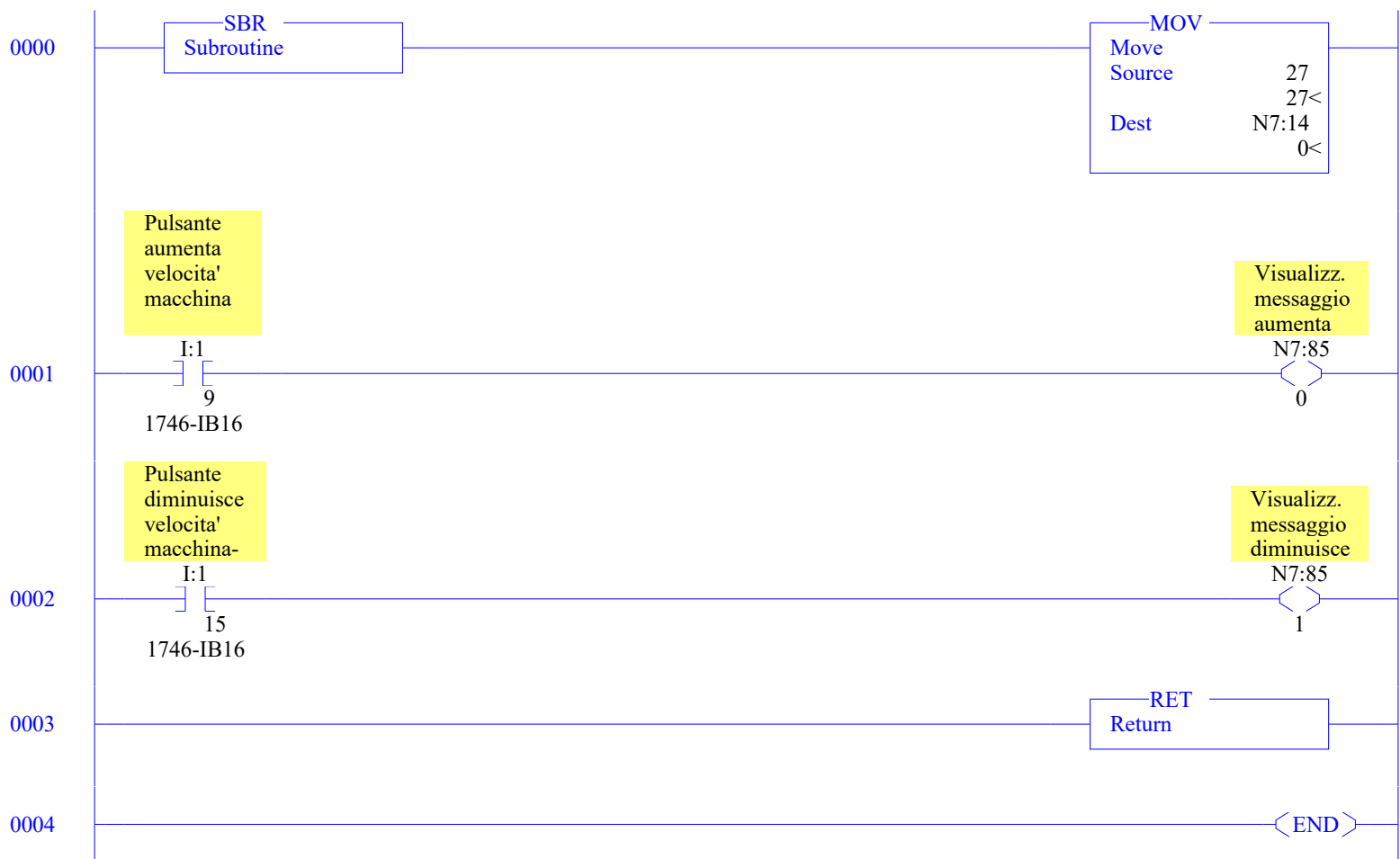

0000

⟨END⟩



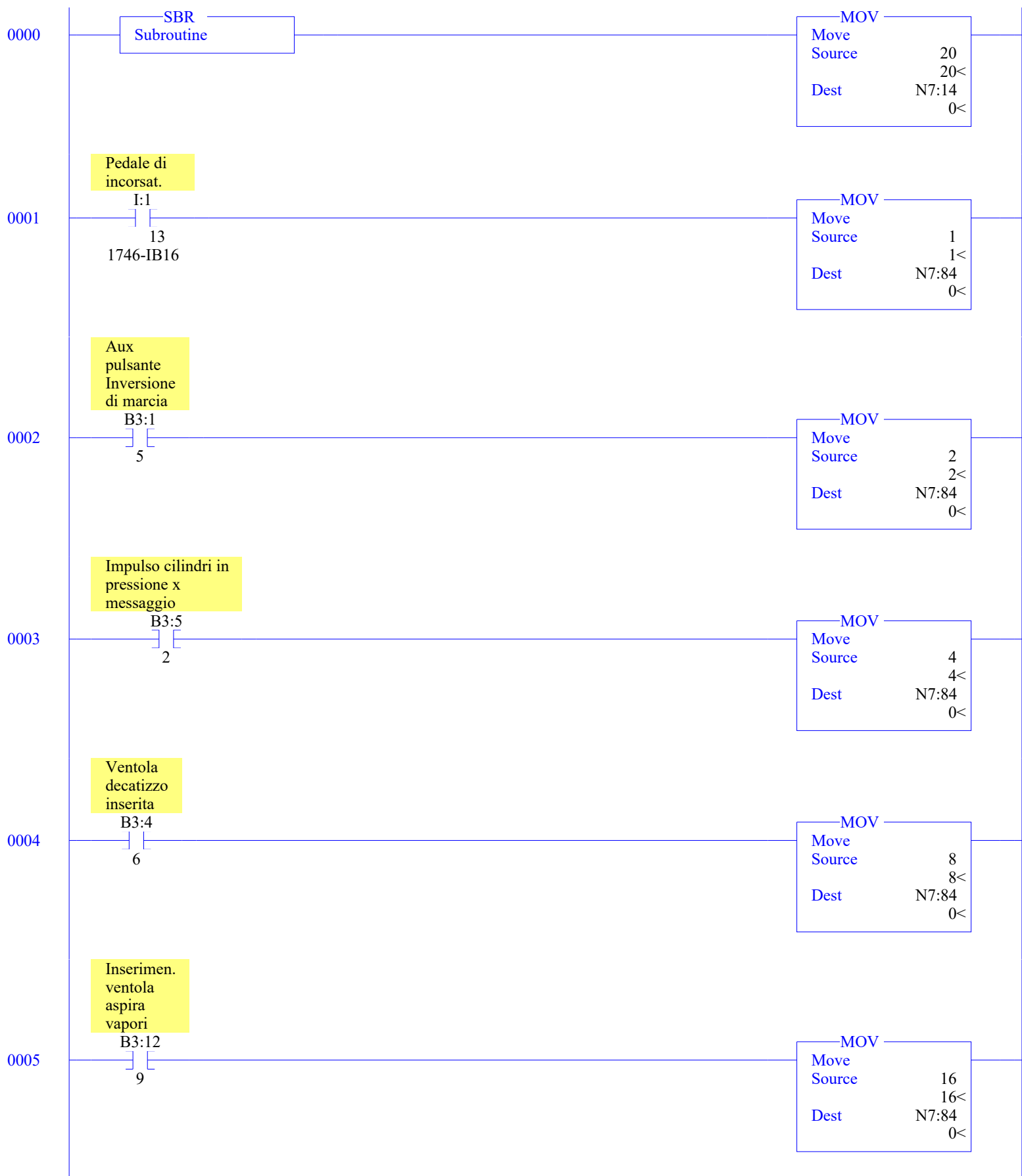



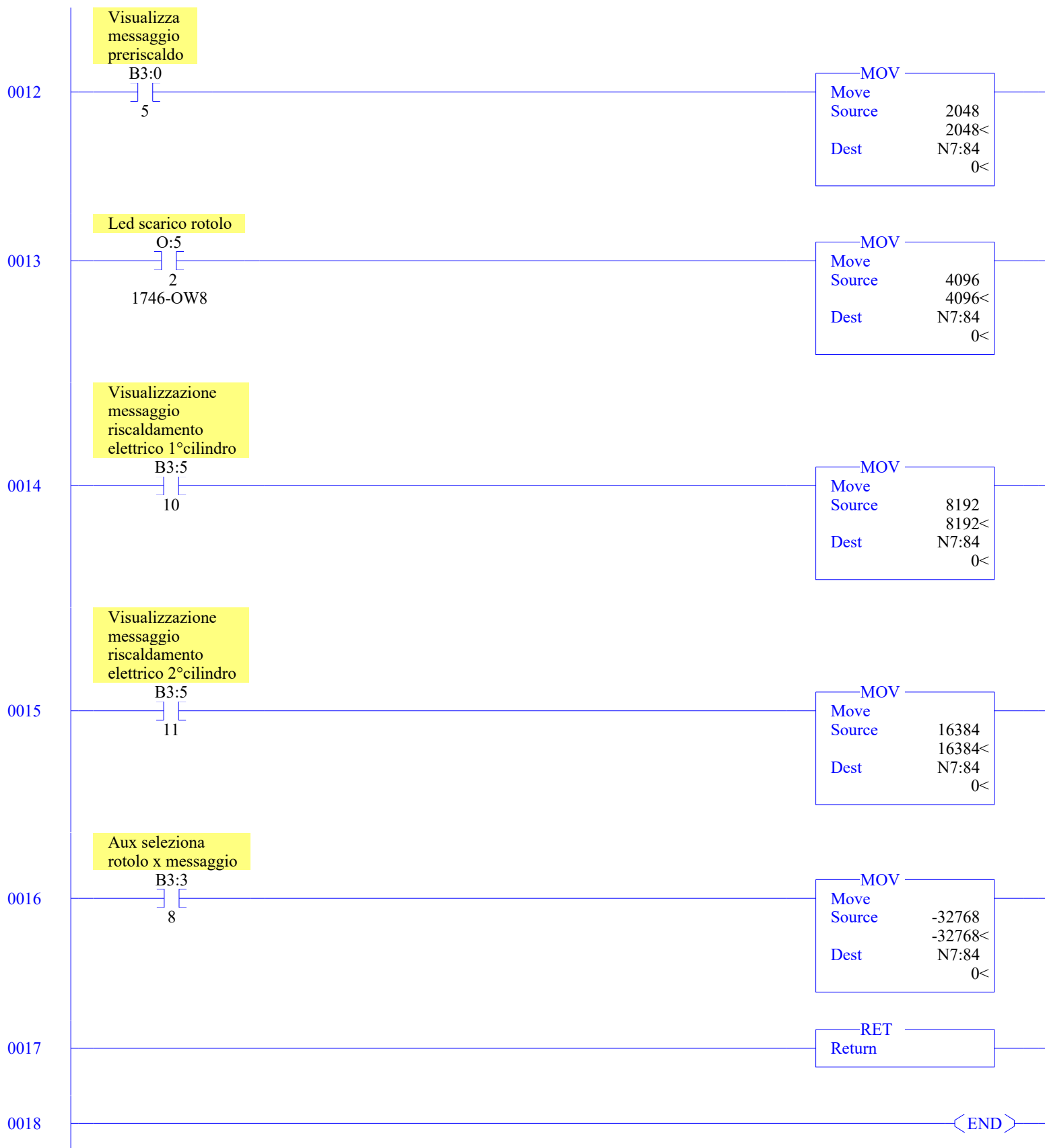

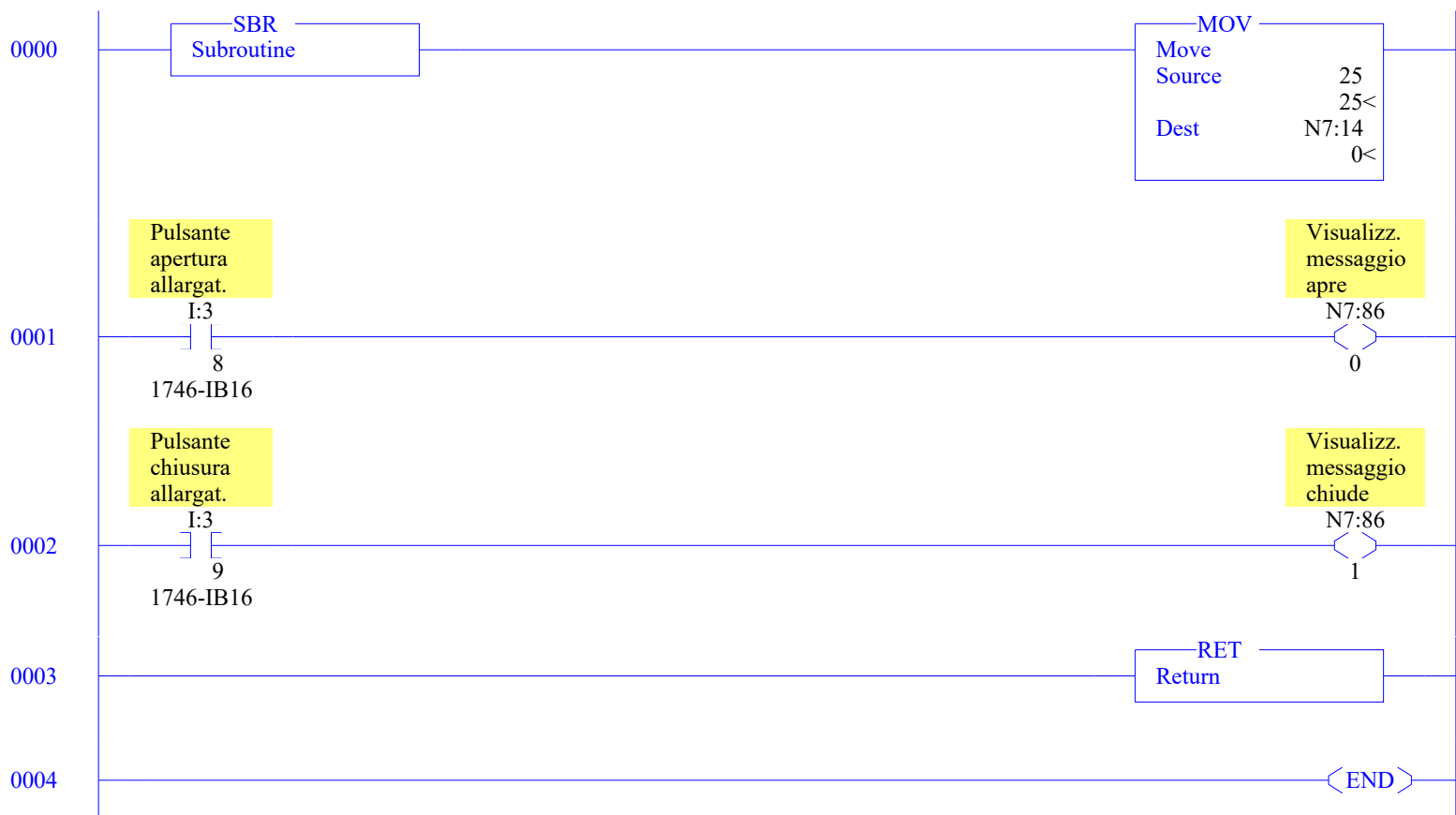

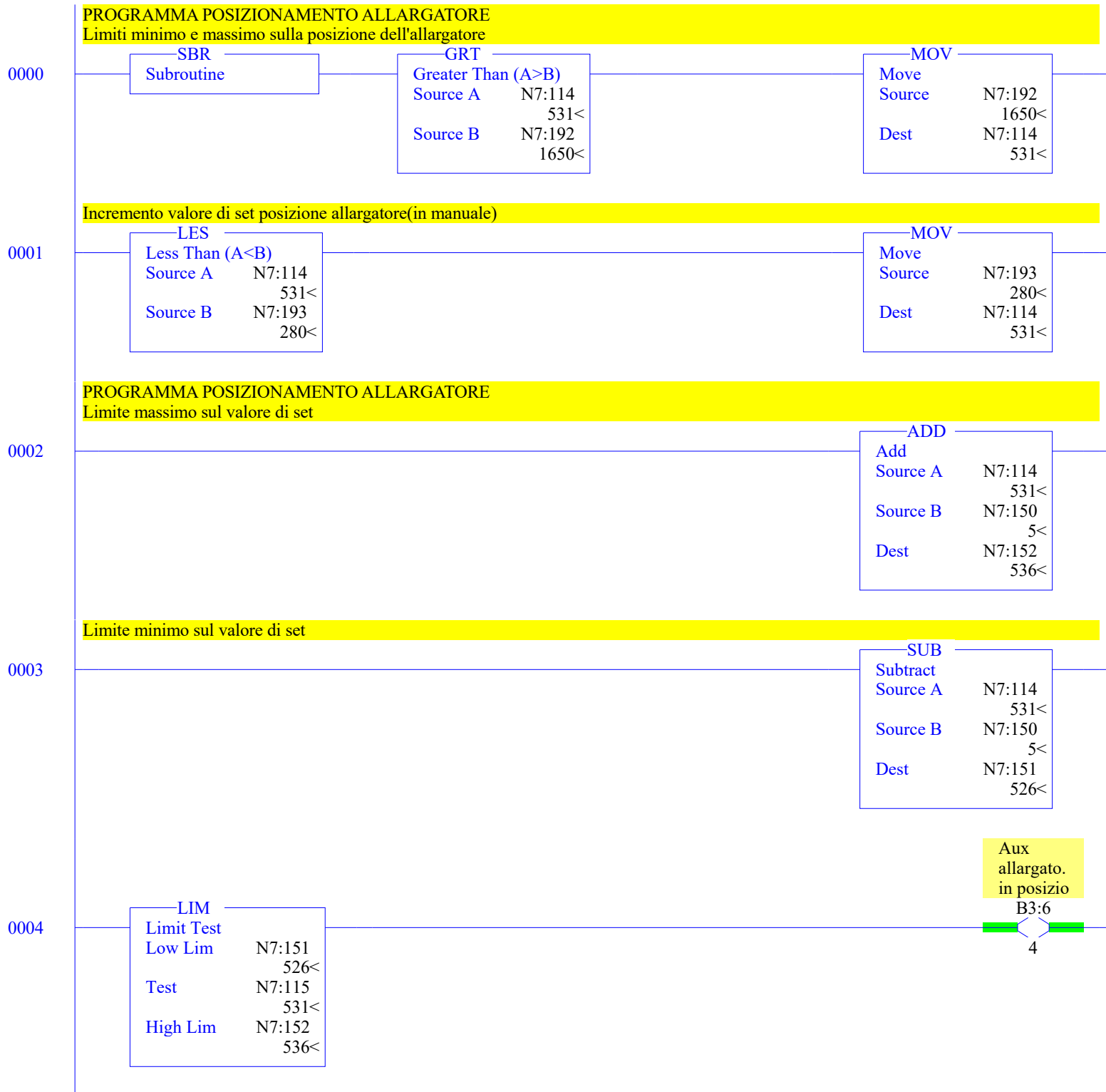

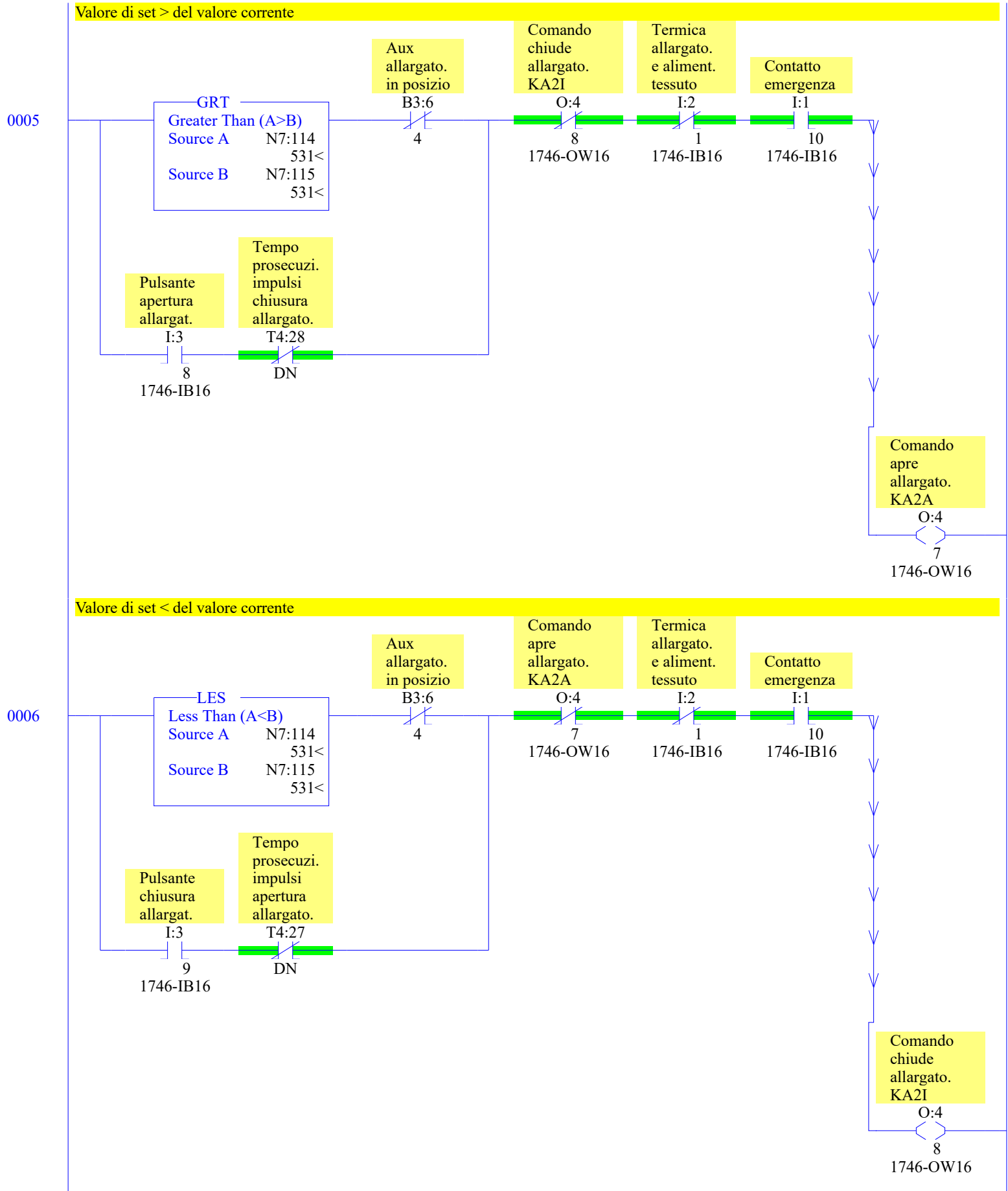

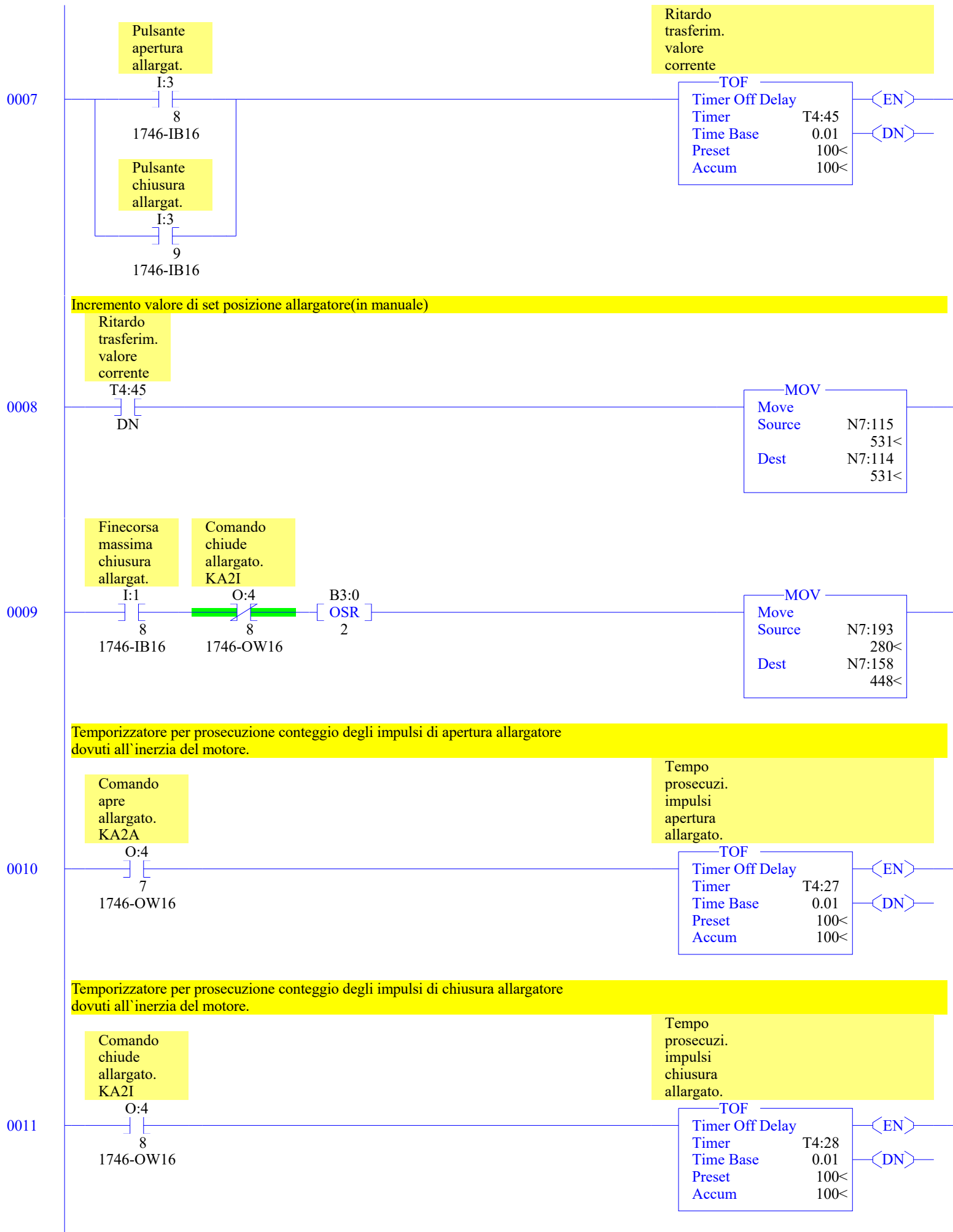

Trasferisco il valore accumulato nella N7:158 nella parola N7:115  
(valore corrente posizione allargatore)

0012

SCP	
Scale w/Parameters	
Input	N7:158 448<
Input Min.	N7:193 280<
Input Max.	N7:156 1197<
Scaled Min.	N7:193 280<
Scaled Max.	N7:192 1650<
Output	N7:115 531<

0013

RET  
Return

0014

⟨END⟩



0000

⟨END⟩



0000

⟨END⟩

0000

⟨END⟩

0000

⟨END⟩

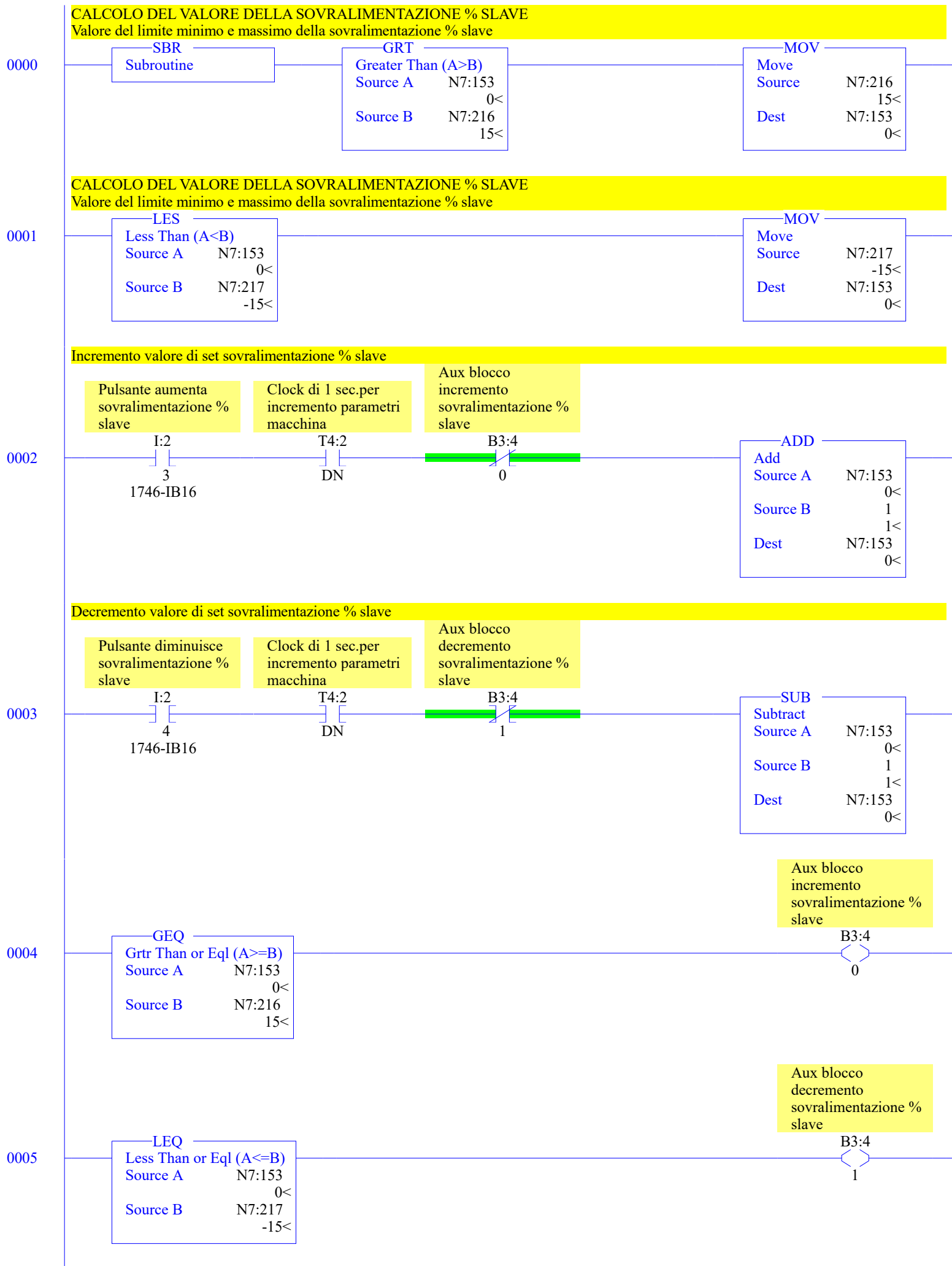

Prendo il valore di set di sovralimentazione % slave(N7:156) gli sommo 100  
 il risultato(N7:218) viene moltiplicato x la velocita' di sovralimentazione %  
 master(N7:165)il tutto viene diviso x 100 e troviamo il valore scalato di  
 sovralimentazione % slave(N7:220)

0006

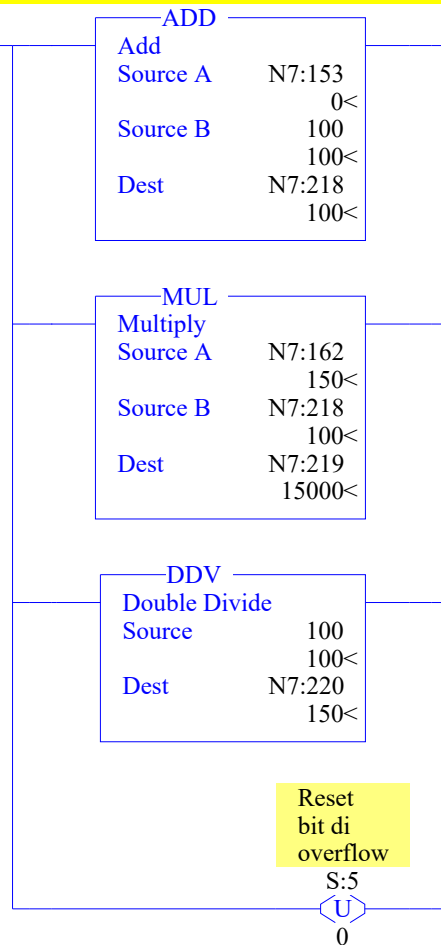

Calcolo uscita analogica della sovralimentazione % slave

0007

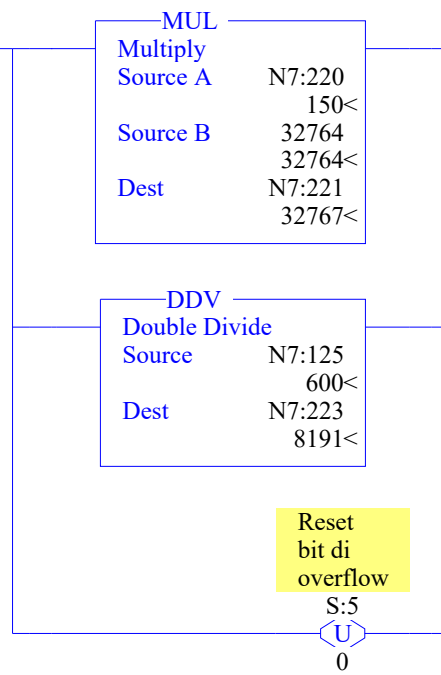
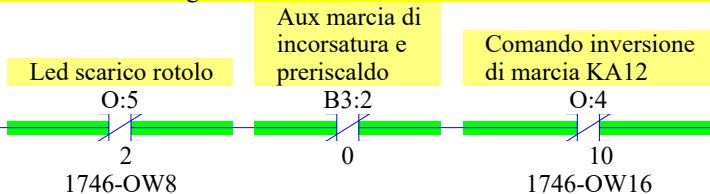

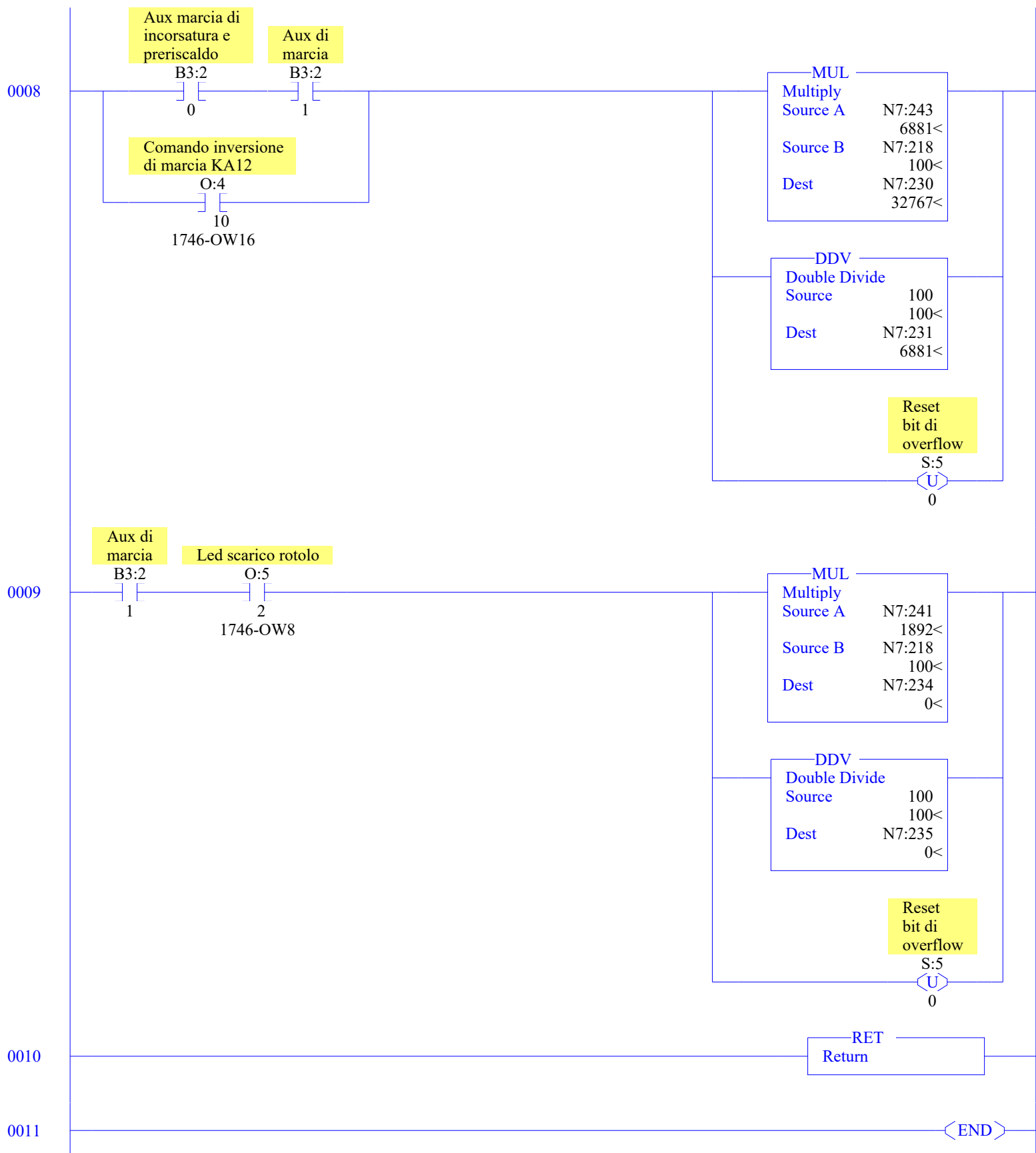



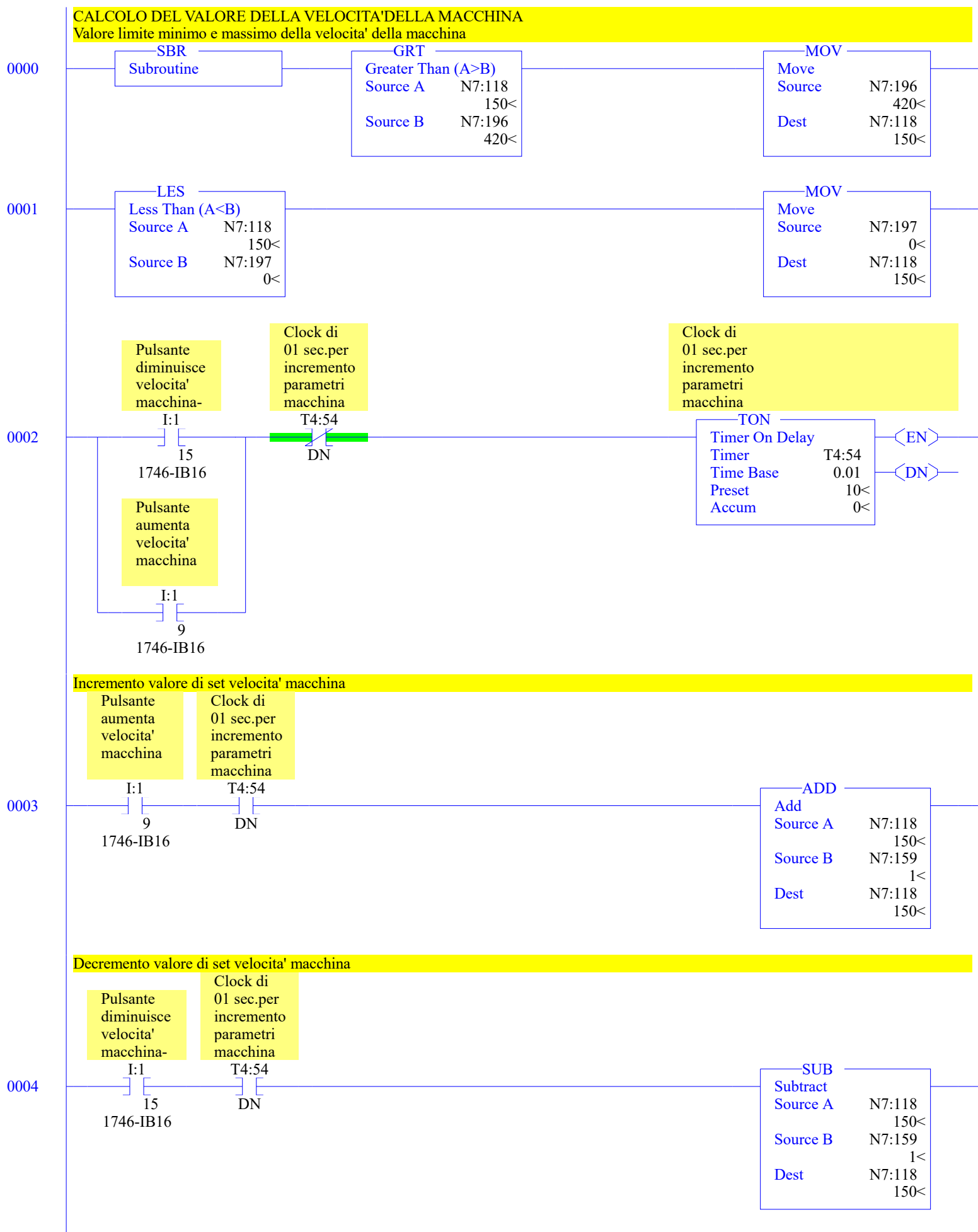

Calcolo del valore analogico della velocita' della macchina  
 Prendo il valore di set della velocita' della macchina(N7:118)lo moltiplico  
 per 32764(valore binario equivalente ai 10 volt analogici)il risultato viene  
 diviso x N7:125(velocita'raggiungibile dalla macchina a 10 volt)e si  
 ottiene il valore binario impostato N7:143

0005

—MUL—	
Multiply	
Source A	N7:118 150<
Source B	32764 32764<
Dest	N7:126 32767<

—DDV—	
Double Divide	
Source	N7:125 600<
Dest	N7:143 8191<

Reset bit di overflow
S:5
U
0

0006

0007

—RET—	
Return	

0008

<END>

**CALCOLO VALORE ANALOGICO SOVRALIMENTAZIONE % MACCHINA**

**Incremento valore di set sovralimentazione %**

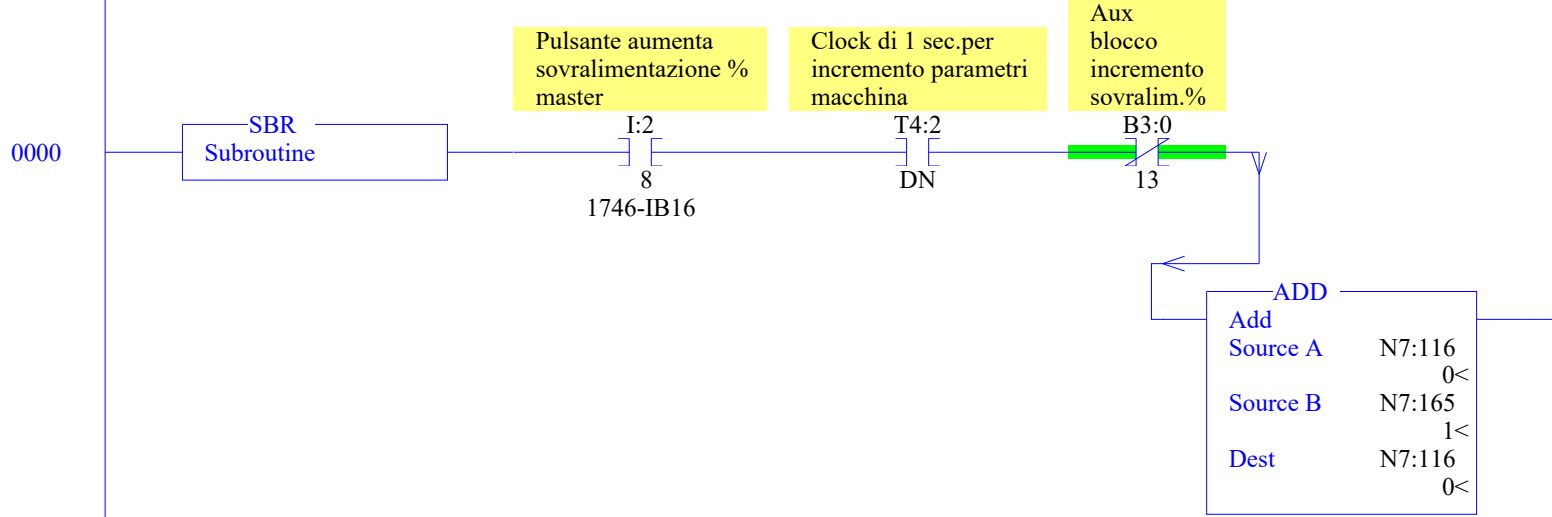

**Decremento valore di set sovralimentazione %**

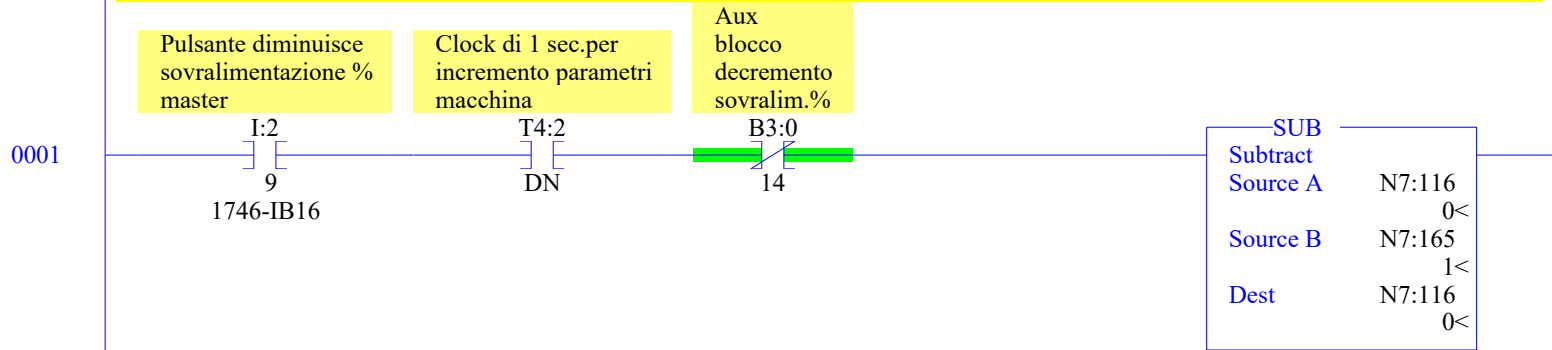

**Se la parola N7:116 e' maggiore o uguale a 30 attivo il merker B3/13**

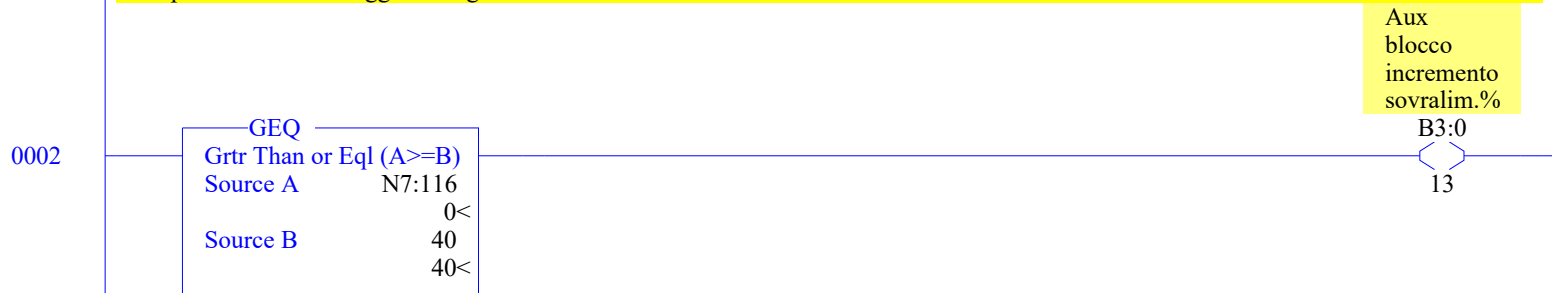

**Se la parola N7:116 e' minore o uguale a -30 attivo il merker B3/14**

